

# *Harmonized System: 2017 version*

By

**H. Mahamoodally (Technical Officer)  
N. Thakoor (Customs Officer II)**

**Tariff Information Unit**



*Partners in Progress and Prosperity*

# HS Nomenclature 2012



**v/s**

# HS Nomenclature 2017

A **structured** Nomenclature comprising:

List of headings arranged in systematic order

**21** Sections of commodity sectors

**96** Chapters (97 excluding Chapter 77)



**1224** Headings ( 4-digit codes)



**5205** Subheadings ( 6-digit codes)

A **structured** Nomenclature comprising:

List of headings arranged in systematic order

**21** Sections of commodity sectors

**96** Chapters (97 excluding Chapter 77)

**1222** Headings ( 4-digit codes)

**5387** Subheadings ( 6-digit codes)

**The Recommendation of the CCC includes 233 sets of amendments divided as follows:**

- **Agricultural sector: 85**
- **Chemical sector: 45**
- **Wood sector: 13**
- **Textile sector: 15**
- **Base metal sector: 6**
- **Machinery sector: 25**
- **Transport sector: 18**
- **Other sectors: 26**

## HS 2017 AMENDMENTS – GENERAL SCOPE

### *Environmental and social issues of global concern*

- **FAO amendments cover : agriculture, fishery and forestry products, fertilisers, agricultural machinery**
- **Antimalaria commodities**
- **Bamboo and Rattan ( INBAR)**
- **Substances controlled under CWC (OPCW)**
- **Substances controlled under Rotterdam Convention (PIC)**
- **Substances controlled under Stockholm Convention (POPs)**
- **Precursors (INCB)**

- **TECHNOLOGICAL PROGRESS** : Newsprint, LED lamps , new technology in the automotive industry, semiconductor technology
- **TRADE PATTERNS**: Deletion of some subheadings due to low volume of trade e.g unglazed ceramic and glazed ceramic
- **CLARIFICATION OF TEXTS**: Definition of infant food, modification of headings 40.10 for pneumatic tyres of rubber, heading 85.28 for monitors and projectors connected to an ADPM, creation of new heading for monopods, bipods and tripods
- **ADAPT NOMENCLATURE TO REFLECT TRADE PRACTICE**: New subheadings for mandarins, clementines, non- alcoholic beer, wine in containers holding less than 10 lts, INN, etc

**6-digit additions : 235**

**6-digit deletions : 73**

**6-digit net change: + 162**

**Subheadings whose code number have remained unchanged though the scope have been modified: 200**

**4-digit heading (NEW): 1.....96.20**

**4-digit headings deleted: 3.....28.48, 69.08, 84.69**



- **Newsprint of heading 48.01: Size criteria**
- **Heading 85.39 : LED lamps**
- **Modification of structure of heading 87.03 and 87.11 regarding technological changes in the automotive industry : Hybrid, plug-in hybrid and all-electric**
- **Heading 85.42 : MCO (Multi-component integrated circuits) manufactured using semiconductor technology**

- **Light-emitting diode (LED) lamps**
- **MCOs (Multi-component Integrated Circuits) MCOs are advanced semiconductor devices, defined in new Note 9 (b)(iv) to Chapter 85**
- **Hybrid, plug-in hybrid and all-electric**

## Deletion of subheading due to low volume of trade

- Headings 69.07 and 69.08 merged (heading 69.08 deleted)
- Distinction between glazed and unglazed ceramic no more applicable within the industry

- **New definition of infant food- amendment of text of subheading Note 1 to Chapter 16, of subheading 1901.10, subheading Notes 1 and 2 to Chapter 20 and Note 3 to Chapter 21**
- **Modification of structure of heading 40.10 for pneumatic tyres**
- **Modification of texts of subheadings of heading 85.28 for monitors and projectors connected to an ADPM**
- **Regrouping of monopods, bipods and tripods in heading 96.20**

**Merging of unglazed and glazed ceramic products (69.07 and 69.08)**

**Infant (as in ‘infant food’)**

**Pneumatic tyres**

**Monitors, projectors**

**Monopods, bipods and tripods and similar articles**

- **New definition of infant food- amendment of text of subheading Note 1 to Chapter 16, of subheading 1901.10, subheading Notes 1 and 2 to Chapter 20 and Note 3 to Chapter 21**
- **Modification of structure of heading 40.10 for pneumatic tyres**
- **Modification of texts of subheadings of heading 85.28 for monitors and projectors connected to an ADPM**
- **Regrouping of monopods, bipods and tripods in heading 96.20**

- ❑ **New headings/subheadings created for:**
  - **Mandarins and clementines in 08.05**
  - **Non-alcoholic beer in heading 22.02**
  - **Wine in containers (more than 2l but not more than 10l) in 22.04**
  - **INN (ubidecarenone) in heading 29.14**
  - **Sucralose in heading 29.32**
  - **Certain copolymers (specific gravity of less than 0.94) in heading 39.01**

# Creation of New Subheadings – Examples

0805.21 -- Mandarins (including tangerines and satsumas)

0805.22 -- Clementines

0805.29 -- Other





## Carps - new families in new subheadings e.g 0301.93, 0302.70

### 03.01

#### Live fish.

- Ornamental fish :

0301.11 -- Freshwater

0301.19 -- Other

- Other live fish :

0301.91 -- Trout (*Salmo trutta*, *Oncorhynchus mykiss*, *Oncorhynchus*  
*Oncorhynchus aguabonita*, *Oncorhynchus gilae*, *Oncorh*  
*apache* and *Oncorhynchus chrysogaster*)

0301.92 -- Eels (*Anguilla* spp.)

0301.93 -- Carpes (*Cyprinus* spp., *Carassius* spp., *Ctenopharyngodon*  
*idellus*, *Hypophthalmichthys* spp., *Cirrhinus* spp.,  
*Mylopharyngodon piceus*, *Catla catla*, *Labeo* spp., *Osteochilus*  
*hasselti*, *Leptobarbus hoeveni*, *Megalobrama* spp.)

0301.94 -- Atlantic and Pacific bluefin tunas (*Thunnus thynnus*, *Thunnus*  
*orientalis*)

0301.95 -- Southern bluefin tunas (*Thunnus maccoyii*)

0301.99 -- Other

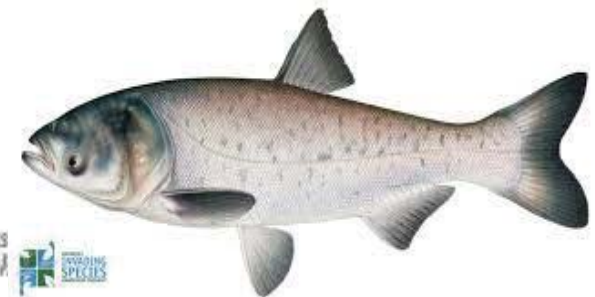

## Edible fish offal

03.02		Fish, fresh or chilled, excluding fish fillets and other fish meat of heading 03.04.
	0302.90	- Livers and roes
03.02		Fish, fresh or chilled, excluding fish fillets and other fish meat of heading 03.04.
	<del>0302.90</del>	- Livers, roes, milt, fish fins, tails, maws and other edible fish offal
	0302.91	-- Livers roes and milt
	0302.92	-- Shark fins
	0302.99	-- Other

## Scope of shark fins

### Subheading Explanatory Note

### Subheadings 0302.92 / 0303.92 / 0305.71

For the purposes of subheading 0302.92, the term “shark fins” covers dorsal, pectoral, ventral, anal fins and the lower lobe of the tail (caudal fin) of sharks.

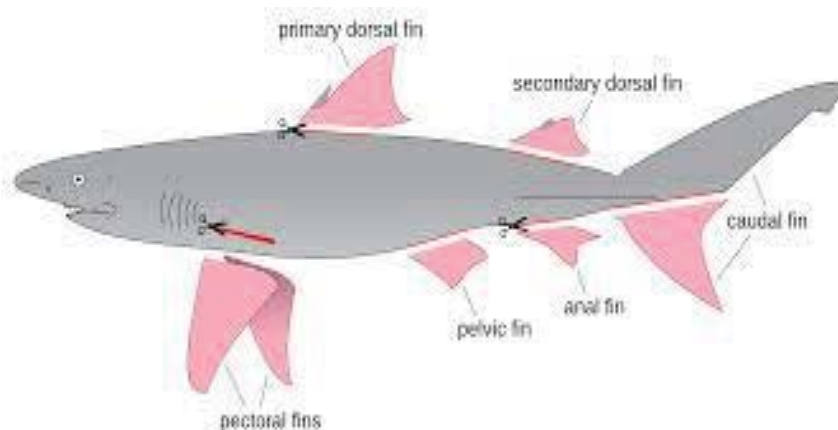

The HS 2017 amendments provides for detailed information regarding several categories of products that are used as antimalarial commodities:

Long Lasting Insecticidal **Nets**(LLIN),

Antimalarial **pharmaceuticals**,

**Insecticides** for Indoor Residual Spraying (IRS),

Rapid Diagnostic **Test Kits** (RDT)

New subheadings: (New Note 2)

3003.60 : Other, containing antimalarial active principles described in Subheading Note 2 to this Chapter

3004.60 : Other, containing antimalarial active principles described in Subheading Note 2 to this Chapter

## New Subheading

**6005.35 – Fabrics** specified in Subheading Note 1 to this Chapter

Chapter 60

New Subheading Note

1. Subheading 6005.35 covers **Fabrics** of polyethylene monofilament or of polyester multifilament, **weighing** not less than 30 g/m<sup>2</sup> and not more than 55 g/m<sup>2</sup>, having **a mesh size** of not less than 20 holes/cm<sup>2</sup> and not more than 100 holes/cm<sup>2</sup>, **and impregnated or coated** with alpha-cypermethrin(ISO), chlorfenapyr(ISO), deltamethrin(INN, ISO), lambda-cyhalothrin(ISO), permethrin (ISO) or pirimiphos-methyl (ISO).



## New Subheading

6304.20 –Bed nets specified in Subheading Note 1 to this Chapter



## CHAPTER 63

### New Subheading Note.

1. Subheading 6304.20 covers articles made from warp knit fabrics, **impregnated or coated with** alpha-cypermethrin(ISO), chlorfenapyr(ISO), deltamethrin(INN, ISO), lambda-cyhalothrin(ISO), permethrin (ISO) or pirimiphosmethyl (ISO)

## CHAPTER 38.

### New Subheading Note 2.

2. Subheadings 3808.61 to 3808.69 cover only goods of heading 38.08, containing alpha-cypermethrin(ISO), bendiocarb(ISO), bifenthrin(ISO), chlorfenapyr(ISO),cyfluthrin(ISO),deltamethrin(INN,ISO),etofenprox(IN N),fenitrothion(ISO),lambda-cyhalothrin(ISO),malathion(ISO), pirimiphosmethyl(ISO) or propoxur(ISO).



**New Subheading :  
3002.11 --Malaria diagnostic test  
kits**



## **Ephedrine, pseudoephedrine and norephedrine**

**Amendments to the HS in respect of certain narcotic substances (proposal by the UN International Narcotics Control Board)**

## Ephedrine, pseudoephedrine and Ephedrine and pseudoephedrine

Ephedra ..... Heading 12.11/ 13.02

Medicaments ..... Heading 30.03/ 30.04



- **Chapter 16**
- **Chapter 19**
- **Chapter 20**
- **Chapter 21**

# Clarification of term “Infant” (cont.)

HS 2012	HS 2017
Infant food	Food suitable for infants and young children
Aliment pour enfants	Aliments pour nourrissons et enfants en bas age

Waters, including mineral waters and aerated waters, containing added sugar or other sweetening matter or flavoured, and other non-alcoholic beverages, not including fruit or vegetable juices of heading 20.09.

- Other:
  - 2202.91 non-alcoholic beer



## Wine (bag-in-box)

2204.22

-- In containers holding more than 2 L but not more than 10 L



22.06	2206.00	Other fermented beverages (for example, cider, perry, mead, saké); mixtures of fermented beverages and mixtures of fermented beverages and non-alcoholic beverages, not elsewhere specified or included:
-------	---------	--





2932.14 -- Sucralose



➤ **New chemicals listed in Annex II to the  
Rotterdam Convention  
Specific HS Codes**

**Some examples:**

**Alachlor**

**Aldicarb**

**Azinphos Methyl**



## Amendments in respect of certain POPs

POPs are toxic organic compounds that resist degradation and accumulate in the food-chain. They can be transported over long distances in the atmosphere, resulting in widespread distribution across the earth.

Persistent Organic Pollutants

Amendments in respect of certain Persistent Organic Pollutants “POPs” (Stockholm Convention)

## Persistent Organic Pollutants(POPs)

**Some examples:**

**2910.50: Endrin**

**2904.33: Lithium perfluorooctane sulphonate**

**2914.71: Chlordecone**

3002.13 -- Immunological products, unmixed, not put up in measured doses or in forms or packings for retail sale

3002.14 -- Immunological products, mixed, not put up in measured doses or in forms or packings for retail sale

3002.15 -- Immunological products, put up in measured doses or in forms or packings for retail sale



## Fertilisers (Proposal by the FAO)

Mineral or chemical fertilisers, phosphatic.

**HS 2012**

**3103.10 - Superphosphates**

Mineral or chemical fertilisers, phosphatic.

**HS 2017**

3103.11 -- Containing by weight 35 % or more of  
diphosphorus pentaoxide (P<sub>2</sub>O<sub>5</sub>)

3103.19 -- Other

## TMQ (rubber additive)

38.12	Prepared rubber accelerators; compound plasticisers for rubber or plastics, not elsewhere specified or included; anti-oxidising preparations and other compound stabilisers for rubber or plastics.
3812.31	-- Mixtures of oligomers of 2,2,4-trimethyl-1,2-dihydroquinoline (TMQ)
3812.39	-- Other

## Linear Low-Density PolyEthylene is often used to make things like plastic films

39.01	Polymers of ethylene, in primary forms.
-------	---



3901.40	- Ethylene-alpha-olefin copolymers, having a specific gravity of less than 0.94
---------	---



4011.70	- Of a kind used on agricultural or forestry vehicles and machines
4011.80	- Of a kind used on construction, mining or industrial handling vehicles and machines
4011.90	- Other

**Tyres grouped on the basis of their perspective uses.**

## Amendments in respect of forestry products (FAO and ITTO). Subheading Note 2 –Tropical wood species (Chapter 44)

### Subheading Notes.

2.- For the purposes of subheadings 4403.41 to 4403.49, 4407.21 to 4407.29, 4408.31 to 4408.39 and 4412.31, the expression "tropical wood" means one of the following types of wood:

Abura, Acajou d'Afrique, Afromosia, Ako, Alan, Andiroba, Aningeré, Avodiré, Azobé, Balau, Balsa, Bossé clair, Bouyer, Bouyer, Doussié, Framiré, Freijo, Freijo, Jelutong, Jequitiba, Jongkong, Meranti, Limba, Louro, Maçaranduba, Mahogany, Makore, Mandioqueira, Mansonia, Mengkulang, Meranti Bakau, Merawan, Merbau, Merpauh, Mersawa, Mutsi, Niangon, Nyatoh, Obeche, Okoumé, Onzabili, Orey, Ovengkol, Ozigo, Padauk, Paldar, Palissandre de Guatemala, Palissandre de Para, Palissandre de Rio, Palissandre de Rose, Pau Amarelo, Pau Marfim, Pulai, Punah, Quaruba, Ramin, Sapelli, Saqui-Saqui, Sepetir, Sipo, Sucupira, Suren, Tauari, Teak, Tiama, Tola, Virola, White Lauan, White Meranti, White Saraya, Yellow Meranti.

**NO DEFINITION OF TROPICAL WOOD**

**List of species in the EN**



The new Version include the creation of new subheadings for the monitoring and control of certain products of bamboo and rattan, requested by the International Network for Bamboo and Rattan (INBAR)

.E.g., bamboo flooring :

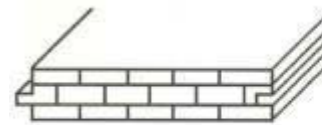

Horizontal



Horizontal Natural



Horizontal Carbonized

**Heading 48.18 in HS 2017**

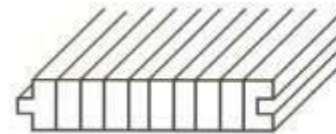

Vertical



Vertical Natural



Vertical Carbonized



**44.19**

**Tableware and kitchenware, of wood.**

**- Of bamboo**

**4419.11 – Bread boards, chopping boards and similar boards**

**4419.12 – Chopsticks**

**4419.19 – Other**

**4419.90 - Other**

## Bamboo and Rattan

44.21		Other articles of wood.
	4421.10	- Clothes hangers
	<del>4421.90</del>	- Other:
	4421.91	-- Of bamboo
	4421.99	-- Other

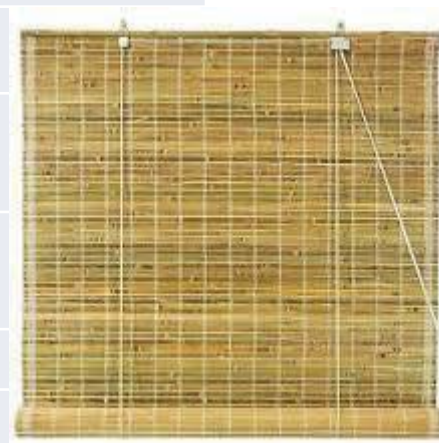

## Bamboo and Rattan



	- Furniture of other materials, including cane, osier, bamboo or similar materials:
<del>9403.81</del>	<del>— Of bamboo or rattan:</del>
<b>9403.82</b>	<b>-- Of bamboo</b>
<b>9403.83</b>	<b>-- Of rattan</b>

HS 2017

## Merging of 69.07 and 69.08

<b>69.07</b>		<b>Ceramic flags and paving, hearth or wall tiles; ceramic mosaic cubes and the like, whether or not on a backing; finishing ceramics.</b>
		- Flags and paving, hearth or wall tiles, other than those of subheadings 6907.30 and 6907.40:
	6907.21	-- Of a water absorption coefficient by weight not exceeding 0.5%
	6907.22	-- Of a water absorption coefficient by weight exceeding 0.5% but not exceeding 10%
	6907.23	-- Of a water absorption coefficient by weight exceeding 10%
	6907.30	- Mosaic cubes and the like, other than those of subheading 6907.40
	6907.40	- Finishing ceramics
	6907.90	- Other

## Chapter 84

Nuclear reactors, boilers, machinery and mechanical appliances;  
parts thereof

Notes

HS 2017

1. This Chapter does not cover:

(g) Radiators for the articles of Section XVII;

E.g., **radiators** of motor  
vehicles and motorcycles are  
classified in Chapter 87.





## Amendments to clarify the classification of certain ceiling or floor types air conditioning machines in subheading 8415.10.

<b>84.15</b>		<b>Air conditioning machines, comprising a motor-driven fan and elements for changing the temperature and humidity, including those machines in which the humidity cannot be separately regulated.</b>
	<b>8415.10</b>	<b>- Of a kind designed to be fixed to a window, wall, ceiling or floor, self-contained or “split-system”:</b>

84.56

**Machine-tools for working any material by removal of material, by laser or other light or photon beam, ultrasonic, electro-discharge, electro-chemical, electron beam, ionic-beam or plasma arc processes; water-jet cutting machines**

8456.11 -- Operated by laser

8456.12 -- Operated by other light or photon beam processes

8456.20 - Operated by ultrasonic processes

8456.30 - Operated by electro-discharge processes

8456.40 - Operated by plasma arc processes

8456.50 - Water-jet cutting machines



# Agricultural Machines and Equipment

84.32		Agricultural, horticultural or forestry machinery for soil preparation or cultivation; lawn or sports-ground rollers
-	<del>8432.30</del>	- Seeders, planters and transplanters:
	8432.31	-- No-till direct seeders, planters and transplanters
	8432.39	-- Other
	<del>8432.40</del>	- Manure spreaders and fertiliser distributors:
	8432.41	-- Manure spreaders
	8432.42	-- Fertiliser distributors

# Agricultural Machines and Equipment (cont.)

	- Other appliances :	
8424.81	-- Agricultural or horticultural	<b>HS 2012</b>
8424.89	-- Other	
	- Agricultural or horticultural sprayers :	
8424.41	-- Portable sprayers	
8424.49	-- Other	
	- Other appliances :	<b>HS 2017</b>
8424.82	-- Agricultural or horticultural	
8424.89	-- Other	

A machining centre is a multi-function machine that typically combines boring, drilling, and milling tasks. In a machining centre, the material is removed by a rotating cutter that moves laterally around the workpiece mounted on a table or fixture. It is based on ADP (Automatic Data Processing) systems.

## ➤ **HS 8465.20: Machining centres**

NEW SUBHEADING NOTE 1 TO CHAPTER 84 :

"1.-For the purposes of subheading 8465.20, the term “machining centres” applies only to machine-tools for working wood, cork, bone, hard rubber, hard plastics or similar hard materials, which can carry out different types of machining operations by automatic tool change from a magazine or the like in conformity with a machining programme."

## Electric accumulators assembled into battery packs

**NO CHANGES** → **HS 2012/ 20177**  
**BUT**

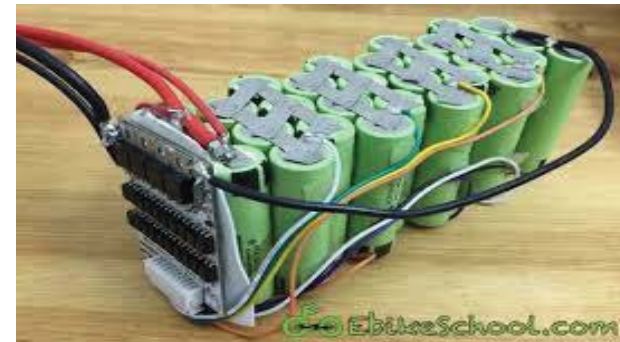

### **NEW NOTE 3 TO CHAPTER 85 :**

3. For the purposes of heading 85.07, the expression “electric accumulators” includes those presented with ancillary components which contribute to the accumulator’s function of storing and supplying energy or protect it from damage, such as electrical connectors, temperature control devices (e.g., thermostats) and circuit protection devices. They may also include a portion of the protective housing of the goods in which they are to be used.

**85.28**

**Monitors and projectors, not incorporating television reception apparatus; reception apparatus for television, whether or not incorporating radio-broadcast receivers or sound or video recording or reproducing apparatus.**

-Cathode-ray tube monitors :

8528.41 -- Of a kind solely or principally used in an automatic data processing system of heading 84.71

8528.49 -- Other

-Other monitors :

8528.51 -- Of a kind solely or principally used in an automatic data processing system of heading 84.71

8528.59 -- Other

-Projectors :

8528.61 -- Of a kind solely or principally used in an automatic data processing system of heading 84.71

8528.69 -- Other



-Cathode-ray tube monitors:

8528.42--Capable of directly connecting to and designed for use with an automatic data processing machine of heading 84.71

-Other monitors:

8528.52--Capable of directly connecting to and designed for use with an automatic data processing machine of heading 84.71

-Projectors:

8528.62--Capable of directly connecting to and designed for use with an automatic data processing machine of heading 84.71

85.39		Electric filament or discharge lamps, including sealed beam lamp units and ultra-violet or infra-red lamps; arc-lamps; light-emitting diode (LED) lamps.
	8539.50	- Light-emitting diode (LED) lamps

LED lamps



**HS Code 8539.50**



## Multi component integrated circuits

Must include an integrated circuit

Must be multi-component (distinct from multi-chip)  
*[i.e. includes other active or passive components as listed in the definition]*

Must be combined to all intents and purposes  
indivisibly

*[i.e., though some of the elements could theoretically be removed and replaced, this would be a long and delicate task which would be uneconomic under normal manufacturing conditions]*

Must be for mounting onto a PCB or other carrier  
*[through connecting of pins, leads, balls, lands, bumps or pads]*

## Is this an MCO?

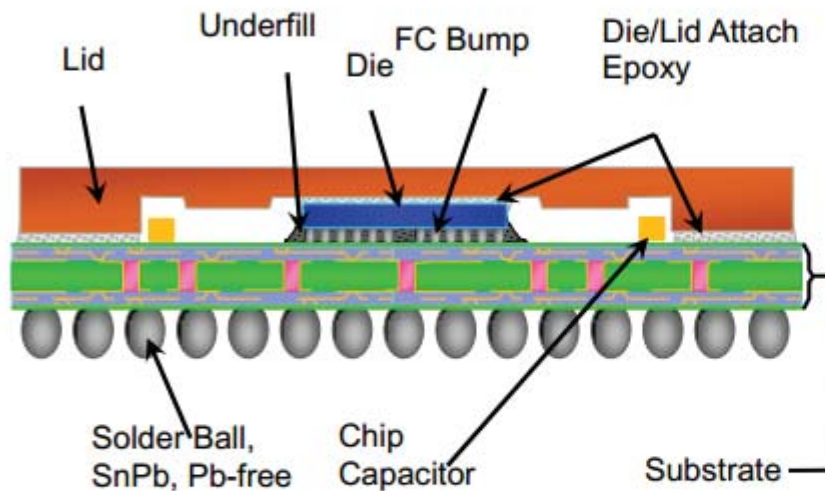

- ✓ The die is an IC
- ✓ The capacitors are other components
- ✓ Indivisible
- ✓ Designed for mounting onto a PCB or other carrier

**Yes, this IS an MCO**

## Is this an MCO?

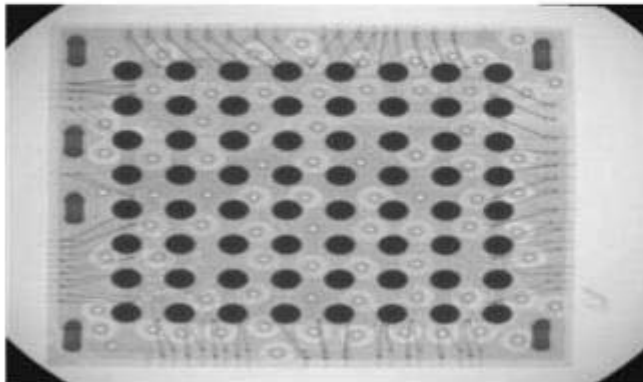
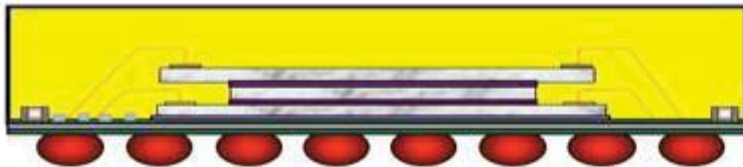

- ✓ The die is an IC
- ✓ The capacitors are other components
- ✓ Indivisible
- ✓ Designed for mounting onto a PCB or other carrier

**Yes, this IS an MCO**

## Is this an MCO?

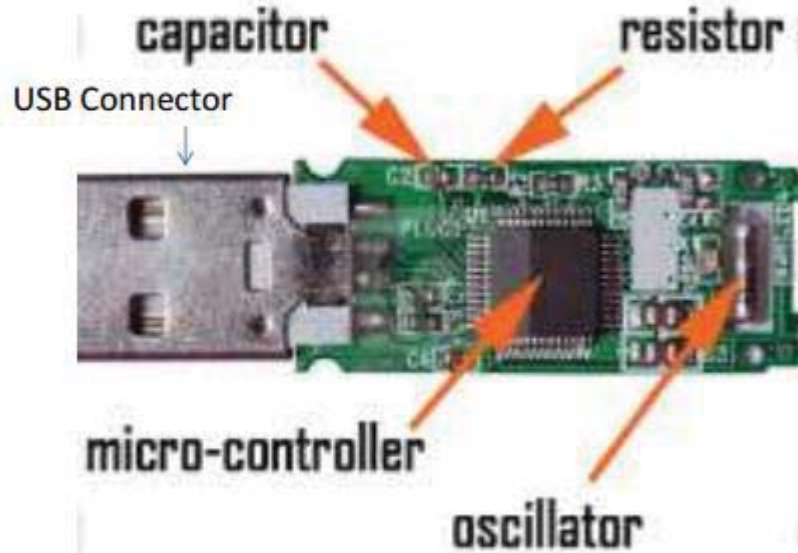

- ✓ The micro controller is a monolithic IC
- ✓ The capacitor, resistor, and oscillator are other components
- x Not Indivisible
- x Is NOT for mounting onto a PCB or other carrier (USB connector)

**No, it is NOT an MCO**

## (Machines and equipment used in agriculture) (Proposed by the FAO)

HS 2012

87.01	Tractors (other than tractors of heading 87.09)
8701.10	- Pedestrian controlled tractors:
8701.20	- Road tractors for semi-trailors:
8701.30	- Track-laying tractors:
8701.90	- Other

<b>8701.10</b>	- Single axle tractors
----------------	------------------------

	- Other, of an engine power:
<b>8701.91</b>	-- Not exceeding 18 kW
<b>8701.92</b>	-- Exceeding 18 kW but not exceeding 37 kW
<b>8701.93</b>	-- Exceeding 37 kW but not exceeding 75 kW
<b>8701.94</b>	-- Exceeding 75 kW but not exceeding 130 kW
<b>8701.95</b>	-- Exceeding 130 kW

HS 2017





# Structure of Heading 87.03 in Tariff 2012

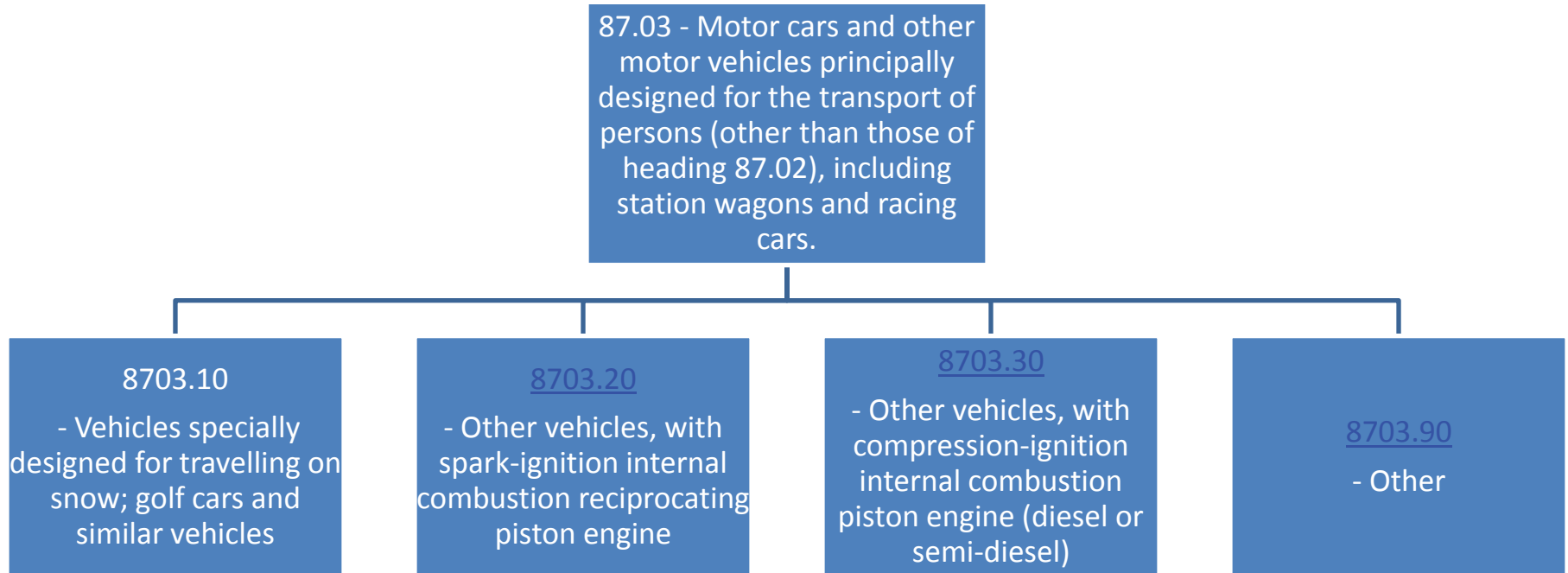

# Types of Vehicles – Classification in Tariff 2012

87.03 - Motor cars and other motor vehicles principally designed for the transport of persons (other than those of heading 87.02), including station wagons and racing cars.

8703.10

- Vehicles specially designed for travelling on snow; golf cars and similar vehicles

8703.20

- Gasoline
- Hybrid Electric Vehicles (HEV)
- Plug-in Hybrid Electric Vehicles (PHEV)
- Biofuels
- Compression Natural Gas (CNG)
- Liquefied Petroleum Gas (LPG)

8703.30

- Diesel/Semi-diesel
- HEV
- PHEV

8703.90

- Battery Electric Vehicles (BEV)

# Structure of Heading 87.03 in Tariff 2017

**87.03**  
 Motor cars and other motor vehicles principally designed for the transport of persons (other than those of heading 87.02), including station wagons and racing cars.

**8703.10.00**  
 - Vehicles specially designed for travelling on snow; golf cars and similar vehicles

**8703.20.00**  
 - Other vehicles, with only spark-ignition internal combustion reciprocating piston engine

**8703.30.00**  
 - Other vehicles, with only compression-ignition internal combustion piston engine (diesel or semi-diesel)

**8703.40.00**  
 - Other vehicles, with both spark-ignition internal combustion reciprocating piston engine and electric motor as motors for propulsion, other than those capable of being charged by plugging to external source of electric power

**8703.50.00**  
 - Other vehicles, with both compression-ignition internal combustion piston engine (diesel or semi-diesel) and electric motor as motors for propulsion, other than those capable of being charged by plugging to external source of electric power

**8703.60.00**  
 - Other vehicles, with both spark-ignition internal combustion reciprocating piston engine and electric motor as motors for propulsion, capable of being charged by plugging to external source of electric power

**8703.70.00**  
 - Other vehicles, with both compression-ignition internal combustion piston engine (diesel or semi-diesel) and electric motor as motors for propulsion, capable of being charged by plugging to external source of electric power

**8703.80.00**  
 - Other vehicles, with only electric motor for propulsion

**8703.90.00**  
 - Other

# Types of Vehicles – Classification in Tariff 2017

87.03

8703.10.00

8703.20.00

- Gasoline
- Biofuels
- CNG
- LPG

8703.30.00

- Diesel/semi-diesel only

8703.40.00

- (Gasoline) HEVs only (Internal Combustion Engine (ICE) + Battery)

8703.50.00

- (Diesel/semi-diesel) HEVs only (ICE + Battery)

8703.60.00

- (Gasoline) PHEVs only (Plug-in + ICE + Battery)

8703.70.00

- (Diesel/semi-diesel) PHEVs only (Plug-in + ICE + Battery)

8703.80.00

- BEVs only (Plug-in + Battery)

8703.90.00

- PHEVs (propelled by battery only)
- Other

Headings	Tariff 2012	Tariff 2017
8703.10.00	-	-
8703.20.00	Gasoline HEV PHEV Biofuels CNG LPG	Gasoline Biofuels CNG LPG
8703.30.00	Diesel HEV PHEV	Diesel only
8703.40.00	-	HEV (Gasoline) only
8703.50.00	-	HEV (Diesel/semi-diesel) only
8703.60.00	-	PHEV (Gasoline) only
8703.70.00	-	PHEV (Diesel/semi-diesel) only
8703.80.00	-	BEV only
8703.90.00	BEV Other	PHEV (propelled by battery only) Other

## HS 2012

94.06 | 9406.00 | **Prefabricated buildings.**

## HS 2017

**"94.06 Prefabricated buildings.**

9406.10 - Of wood

9406.90 - Other".

For the purposes of classification in subheading 9406.10, the expression "of wood" refers to prefabricated buildings with wooden structure, exterior walls, floor (if floor present), and other characteristic constructive elements consisting predominantly of wood.

## Chapter 95

### Notes.

1.-This Chapter does not cover:

(...)

(...)

(e) Sports clothing or fancy dress,  
of textiles, of Chapter 61 or 62;



**NOTE: Amendments in respect of Note 1 to Chapter 95**

## Chapter 95

### Notes.

1. – This Chapter does not cover:

(...)

(...)

(e) Fancy dress of textiles, of Chapter 61 or 62; **sports clothing** and special articles of apparel of textiles, of Chapter 61 or 62, whether or not incorporating incidentally protective components such as pads or padding in the elbow, knee or groin areas (for example, fencing clothing or soccer goalkeeper jerseys);



96.20	9620.00	Monopods, bipods, tripods and similar articles.
-------	---------	---

