

Crypto-Asset Reporting Framework XML Schema (July 2025)

User Guide for Tax Administrations

July 2025

Crypto-Asset Reporting Framework XML Schema

User Guide for Tax Administrations

July 2025

This document and related XML Schema, as well as any data included herein, are without prejudice to the status of or sovereignty over any territory, to the delimitation of international frontiers and boundaries and to the name of any territory, city or area.

This document was approved and declassified by the Committee on Fiscal Affairs on 28 July 2025 and prepared for publication by the OECD Secretariat.

Please cite this publication as:

OECD (2025), *Crypto-Asset Reporting Framework XML Schema (July 2025): User Guide for Tax Administrations*, OECD Publishing, Paris, <https://doi.org/10.1787/6e60235b-en>.

Amendments incorporated in this version: Page 4 :

Change in title of Annex A within the table of contents from v.1.4 to v.1.5.

Page 10:

Inclusion of table for element IIN:

Element	Attribute	Size	Input Type	Requirement
IIN		1 to 200 characters	carf:IndividualIN_Type	Optional (Mandatory)

Page 33:

Change in title of Annex A from v.1.4 to v.1.5.

Page 38:

Change of diagram

The statistical data for Israel are supplied by and under the responsibility of the relevant Israeli authorities. The use of such data by the OECD is without prejudice to the status of the Golan Heights, East Jerusalem and Israeli settlements in the West Bank under the terms of international law.

Note by Türkiye

The information in the related XML Schema with reference to “Cyprus” relates to the southern part of the Island. There is no single authority representing both Turkish and Greek Cypriot people on the Island. Türkiye recognises the Turkish Republic of Northern Cyprus (TRNC). Until a lasting and equitable solution is found within the context of the United Nations, Türkiye shall preserve its position concerning the “Cyprus issue”.

Note by all the European Union Member States of the OECD and the European Union

The Republic of Cyprus is recognised by all members of the United Nations with the exception of Türkiye. The information in the related XML Schema relates to the area under the effective control of the Government of the Republic of Cyprus.

Photo credits: © Shutterstock/optimarc

© OECD 2025



Attribution 4.0 International (CC BY 4.0)

This work is made available under the Creative Commons Attribution 4.0 International licence. By using this work, you accept to be bound by the terms of this licence (<https://creativecommons.org/licenses/by/4.0/>).

Attribution – you must cite the work.

Translations – you must cite the original work, identify changes to the original and add the following text: *In the event of any discrepancy between the original work and the translation, only the text of original work should be considered valid.*

Adaptations – you must cite the original work and add the following text: *This is an adaptation of an original work by the OECD. The opinions expressed and arguments employed in this adaptation should not be reported as representing the official views of the OECD or of its Member countries.*

Third-party material – the licence does not apply to third-party material in the work. If using such material, you are responsible for obtaining permission from the third party and for any claims of infringement. You must not use the OECD logo, visual identity or cover image without express permission or suggest the OECD endorses your use of the work.

Any dispute arising under this licence shall be settled by arbitration in accordance with the Permanent Court of Arbitration (PCA) Arbitration Rules 2012. The seat of arbitration shall be Paris (France). The number of arbitrators shall be one.

Foreword

This document contains a technical update to the user guide for the XML schema that supports the automatic exchange of information pursuant to the Crypto-Asset Reporting Framework (CARF).

This update includes a number of technical adjustments building on the previous user guide approved in 2024. While the XML schema has been primarily designed to facilitate the exchanges of CARF information between tax administrations, the XML schema can also be used for domestic reporting of CARF information by Reporting Crypto-Asset Service Providers, to the extent permitted under domestic law of the relevant jurisdiction.

Table of contents

Foreword	3
Abbreviations and Acronyms	5
CARF XML Schema	6
Introduction	6
CARF Schema Information	8
Corrections	29
Annex A. CARF XML Schema v. 1.5 Diagrams	33
Annex B. Glossary of Namespaces	46

Abbreviations and Acronyms

CA	Competent Authority
CARF	Crypto-Asset Reporting Framework
CARF MCAA	Multilateral Competent Authority Agreement on Automatic Exchange of Information pursuant to the Crypto-Asset Reporting Framework
CRS	Common Reporting Standard
CTS	Common Transmission System
OECD	Organisation for Economic Co-operation and Development
RCASP	Reporting Crypto-Asset Service Provider
XML	Extensible Mark-up Language

CARF XML Schema

Introduction

How the CARF User Guide links to the CARF XML Schema

The Schema for exchanges pursuant to the Crypto-Asset Reporting Framework (CARF) User Guide is divided into logical sections based on the schema and provides information on specific data elements and any attributes that describe each data element.

The main sections of the CARF Schema User Guide are:

- I. The Message Header with the sender, recipient, message type and reporting period;
- II. The Organisation Party type, used for identifying entities, i.e. both Entity Reporting Crypto-Asset Service Providers and Entity Crypto-Asset Users;
- III. The Person Party type, used for identifying individual Reporting Crypto-Asset Service Providers and individual Crypto-Asset Users, as well as the natural persons controlling certain Entity Crypto-Asset Users;
- IV. The CARF Body, which contains two sub-sections –
 - a. RCASP, containing the required information with respect to the identity of the Reporting Crypto-Asset Service Provider that is reporting pursuant to the CARF and its nexus to the reporting jurisdiction;
 - b. Crypto Users, containing information on the Reportable Users’
 - i. Identity, which identifies the individual or Entity Crypto-Asset User (and any Controlling Persons) subject to exchange under the CARF; and
 - ii. Relevant Transactions, which includes information on the Relevant Transactions carried out by a Crypto-Asset User that are reportable under the CARF, namely exchanges between Relevant Crypto-Assets and Fiat Currencies, exchanges between one or more forms of Relevant Crypto-Assets and Transfers (including Reportable Retail Payment Transactions and Transfers to unhosted wallets) of Relevant Crypto-Assets.

The CARF XML Schema is designed to be used for the exchange of information reported under the CARF between competent authorities that have activated exchange relationships under the Multilateral Competent Authority Agreement on Automatic Exchange of Information pursuant to the Crypto-Asset Reporting Framework (“CARF MCAA”), or a similar exchange instrument.

Where appropriate, jurisdictions could also consider using the schema domestically for the purpose of gathering the required information from their respective Reporting Crypto-Asset Service Providers. Sections of the User Guide that relate to the domestic use of the schema are reflected in italics.

The requirement field for each data element and its attribute indicate whether the element is validation or optional in the schema. Every element is one or the other in the schema.

“Validation” elements MUST be present for ALL data records in a file and an automated validation check can be undertaken. The Sender should do a technical check of the data file content using XML tools to make sure all “Validation” elements are present and if they are not, correct the file. The Receiver may also do so and, if incorrect, may reject the file. Where there is a choice between two validation elements under a validation parent and only one is needed, this is shown as “Validation (choice)”.

There may be different business rules for elements that are optional in the schema:

- Some optional fields are shown as “(Optional) Mandatory” – an optional element that is required for CARF reporting as specified in the CARF reporting requirements depending on availability of information or legal factors. Mandatory elements may be present in most (but not all) circumstances, so there cannot be a simple IT validation process to check these. For example, the CARF provides an exception with respect to place of birth information, which is not required to be reported, unless the Reporting Crypto-Asset Service Provider is otherwise required to obtain and report it under domestic law and it is available in the electronically searchable data maintained by the Reporting Crypto-Asset Service Provider.
- Optional elements may be provided, but are not required to be completed.
- Certain elements may be included in the CARF schema for structural consistency with other schemas, but are not required (e.g. the nationality element). This information should not be reported in a CARF schema file and these elements are indicated as “Optional (non-CARF)”.

Appendix A to the CARF User Guide shows a diagrammatic representation of the CARF XML Schema with all its elements.

Appendix B to the CARF User Guide contains a Glossary of namespaces for the CARF XML Schema.

CARF Schema Information

I. Message Header

The information in the message header identifies the tax administration that is sending the CARF message. It specifies when the message was created, what reporting period the report is for, and the nature of the report (original, correction, deletion, etc.).

Element	Attribute	Size	Input Type	Requirement
SendingEntityIN		1 to 200 characters	stf:StringMin1Max200_Type	Optional

Although not used for exchanges between Competent Authorities under the CARF MCAA, for domestic reporting, this data element can be used in case the schema is mandated for domestic reporting by Reporting Crypto-Asset Service Providers to their tax administration. In such instances, it identifies the Reporting Crypto-Asset Service Provider sending the message through a domestically-defined identification number.

Element	Attribute	Size	Input Type	Requirement
TransmittingCountry		2-character	iso:CountryCode_Type	Validation

This data element identifies the jurisdiction of the Competent Authority transmitting the CARF message.

It uses the 2-character alphabetic country code and country name list¹ based on the ISO 3166-1 Alpha 2 standard.

Element	Attribute	Size	Input Type	Requirement
ReceivingCountry		2-character	iso:CountryCode_Type	Validation

This data element identifies the jurisdiction of the Competent Authority receiving the CARF message.

It uses the 2-character alphabetic country code and country name list based on the ISO 3166-1 Alpha 2 standard.

Element	Attribute	Size	Input Type	Requirement
MessageType			carf:MessageType_EnumType	Validation

This data element specifies the type of message being sent. The only allowable entry for messages exchanged under the CARF in this field is "CARF".

Element	Attribute	Size	Input Type	Requirement
Warning		1 to 4'000 characters	stf:StringMin1Max4000_Type	Optional

This data element is a free text field allowing input of specific cautionary instructions about the use of the CARF message content, for example terms of the Instrument or Convention under which the data is exchanged.

Element	Attribute	Size	Input Type	Requirement
Contact		1 to 4'000 characters	stf:StringMin1Max4000_Type	Optional

This data element is a free text field allowing input of specific contact information relating to the sender of the message.

¹ The following disclaimer refers to all uses of the ISO country code list in the CARF Schema. For practical reasons, the list is based on the ISO 3166-1 country list. The use of this list does not imply the expression by the OECD of any opinion whatsoever concerning the legal status of the territories listed. Its content is without prejudice to the status of or sovereignty over any territory, to the delimitation of international frontiers and boundaries and to the name of any territory, city or area.

In international exchanges, this data element contains the contact details of the sending Competent Authority.

Element	Attribute	Size	Input Type	Requirement
MessageRefID		1 to 170 characters	stf:StringMin1Max170_Type	Validation

This data element is a free text field capturing the sender's unique message identifier (created by the sender) that identifies the particular message being sent. The identifier allows both the sender and receiver to identify the specific message later, if questions arise. The Message RefID must start with the country code of the sending jurisdiction, then the year of the reportable period, then the receiving country code before a unique identifier. An example of such identifier is provided in the Corrections section below.

Element	Attribute	Size	Input Type	Requirement
MessageTypeIndic			carf:CARFMessageTypeIndic_EnumType	Validation

This data element specifies the type of information that is sent, i.e. whether it is new information or whether the message seeks to correct or delete previously sent information. As such, the possible values:

- CARF701 – The message contains new information
- CARF702 – The message contains corrections/deletions for previously sent information. When the MessageTypeIndic is CARF702, the DocTypeIndic can contain either Corrections (OECD2) or Deletions (OECD3) or both, but new data (OECD1) cannot be contained. Note that OECD0 can be included for RCASP's DocTypeIndic.
- CARF703 – The message advises that there is no data to report. The value CARF703 may be selected in the following cases:
 - a) in an international context, where the Sending Country wishes to communicate to the Receiving Country that no data on Crypto-Asset Users is to be exchanged for the Reportable Period to which the message relates, in which case the CARF Body element should be omitted; and
 - b) *in a domestic context, where there is no information to be reported by a Reporting Crypto-Asset Service Provider (domestic nil reporting), in which case the CARF Body is only to be populated with respect to the information on the Reporting Crypto-Asset Service Provider.*

Element	Attribute	Size	Input Type	Requirement
ReportingPeriod			xsd:date	Validation

This data element identifies the last day of the reporting period (normally a tax year) to which the message relates in yyyy-MM-DD format. For example, if the information relates to the reporting period ending on 31 December 2027, the field would read "2027-12-31".

Element	Attribute	Size	Input Type	Requirement
Timestamp			xsd:dateTime	Validation

This data element identifies the date and time when the message was compiled. It is anticipated that this element will be automatically populated by the host system. The format for use is yyyy-MM-DD'T'hh:mm:ss.nnn. Fractions of seconds may be used (in such a case the milli-seconds will be provided on 3 digits, see ".nnn" in the format above). Examples: 2027-03-15T09:45:30 or 2027-03-15T09:45:30.789 (with milli-seconds).

II. Organisation Party Type

The organisation type defines the information to be included in the CARF XML Schema in relation to an Entity, in particular an Entity Reporting Crypto-Asset Service Provider or Entity Crypto-Asset User.

It is comprised of the following elements, of which details are set out further below:

Element	Attribute	Size	Input Type	Requirement
ResCountryCode		2-character	iso:CountryCode_Type	Validation

Element	Attribute	Size	Input Type	Requirement
TIN		1 to 200 characters	carf:TIN_Type	Validation

Element	Attribute	Size	Input Type	Requirement
IN		1 to 200 characters	carf:OrganisationIN_Type	Optional (Mandatory)

Element	Attribute	Size	Input Type	Requirement
IIN		1 to 200 characters	carf:IndividualIN_Type	Optional (Mandatory)

Element	Attribute	Size	Input Type	Requirement
Name		1 to 200 characters	carf:NameOrganisation_Type	Validation

Element	Attribute	Size	Input Type	Requirement
Address			carf:Address_Type	Validation

ResCountryCode

Element	Attribute	Size	Input Type	Requirement
ResCountryCode		2-character	iso:CountryCode_Type	Validation

This repeatable data element describes the residence country code(s) of the Entity. In case of an Entity Crypto-Asset User this should always be present and should correspond to the jurisdiction(s) of tax residence identified on the basis of the due diligence requirements of the CARF. When more than one jurisdiction of tax residence is identified, all such jurisdictions should be reported.

In case of an Entity Reporting Crypto-Asset Service Provider, the residence country code should correspond to the sending jurisdiction where the Entity Reporting Crypto-Asset Service Provider has a nexus for reporting purposes under the CARF.

TIN (TIN_Type)

Element	Attribute	Size	Input Type	Requirement
TIN		1 to 200 characters	carf:TIN_Type	Validation

This repeatable data element provides the tax identification number (TIN) used by the tax administration of the jurisdiction of residence of the Entity. In case an Entity Crypto-Asset User does not have a TIN because one was not issued by the reportable jurisdiction or the domestic law of the reportable jurisdiction does not require the collection of the TIN, the value "NOTIN" should be entered and the Unknown attribute (see below) must be set to "true". In the case of an Entity Reporting Crypto-Asset Service Provider, if TIN is not known to the sending Competent Authority, the value "NOTIN" should be entered and the Unknown attribute (see below) must be set to "true". Furthermore, in case more than one TIN is provided, any provided element cannot be flagged as "unknown". This element must be present for both Entity Reporting Crypto-Asset Service Providers and Entity Crypto-Asset Users.

Element	Attribute	Size	Input Type	Requirement
TIN	issuedBy	2-character	iso:CountryCode_Type	Optional (Mandatory)

This attribute describes the jurisdiction that issued the TIN. It should always be provided, unless the TIN element is flagged as “unknown”.

Element	Attribute	Size	Input Type	Requirement
TIN	unknown	1-4 character	xsd:Boolean	Optional(Mandatory)

This attribute should be provided if the TIN is not available or inexistent. Any value provided for a TIN flagged as unknown will be discarded. The value for True is “true” and “1”.

Entity IN (OrganisationIN_Type)

Element	Attribute	Size	Input Type	Requirement
IN		1 to 200 characters	carf:OrganisationIN_Type	Optional(Mandatory)

This data element can be provided (and repeated) if there are other INs available, such as a company registration number or an Entity Identification Number (EIN).

Element	Attribute	Size	Input Type	Requirement
IN	issuedBy	2-character	iso:CountryCode_Type	Optional

This attribute describes the jurisdiction that issued the IN. If the issuing jurisdiction is not known then this element may be omitted.

Element	Attribute	Size	Input Type	Requirement
IN	INType		carf:INType_EnumType	Optional

This attribute defines the type of identification number being sent among the following:

- LEI for the reporting of a legal entity identifier that is a unique global identifier for legal entities participating in financial transactions and is formatted as a 20-character alpha-numeric code based on the ISO 17442 standard;
- EIN for the reporting of an entity identification number;
- BRN for the reporting of a business registration number; or
- Other.

Individual IN

Element	Attribute	Size	Input Type	Requirement
IIN		1 to 200 characters	carf:IndividualIN_Type	Optional (Mandatory)

[EU-Specific] This data element should be provided if an Individual Identification Number is available in respect of an Entity Crypto-Asset Service Provider.

Element	Attribute	Size	Input Type	Requirement
IIN	issuedBy	2-character	iso:CountryCode_Type	Optional (Mandatory)

This attribute describes the jurisdiction that issued the IIN. If the issuing jurisdiction is not known then this element may be omitted.

Organisation Name

Element	Attribute	Size	Input Type	Requirement
Name		1 to 200 characters	carf:NameOrganisation_Type	Validation

This element should contain the legal name of the Entity, including the domestic designation for the legal form, as indicated in its articles of incorporation or any similar document.

Address (Address_Type)

Element	Attribute	Size	Input Type	Requirement
CountryCode		2-character	iso:CountryCode_Type	Validation

This data element provides the country code associated with the Entity's (or person's) address.

Element	Attribute	Size	Input Type	Requirement
AddressFix			carf:AddressFix_Type	Validation

This data element requires the input of address information in fixed format.

Element	Attribute	Size	Input Type	Requirement
AdditionalAddressInfo		1 to 4'000 characters	stf:StringMin1Max4000_Type	Optional

This data element can only be used in addition to an address in a fixed format, where not all information can be entered in a fixed format.

Element	Attribute	Size	Input Type	Requirement
Address	legalAddressType		carf:OECDLegalAddressType_EnumType	Optional

OECDLegalAddressType_EnumType

This is a datatype for an attribute to an address. It serves to indicate the legal character of that address (residential, business etc.).

The possible values are:

- OECD301= residentialOrBusiness
- OECD302= residential
- OECD303= business
- OECD304= registeredOffice
- OECD305= unspecified

Address Fix (AddressFix_Type)

Element	Attribute	Size	Input Type	Requirement
Street		1 to 200 characters	stf:StringMin1Max200_Type	Optional(Mandatory)

Element	Attribute	Size	Input Type	Requirement
BuildingIdentifier		1 to 200 characters	stf:StringMin1Max200_Type	Optional(Mandatory)

Element	Attribute	Size	Input Type	Requirement
SuiteIdentifier		1 to 200 characters	stf:StringMin1Max200_Type	Optional(Mandatory)

Element	Attribute	Size	Input Type	Requirement
FloorIdentifier		1 to 200 characters	stf:StringMin1Max200_Type	Optional(Mandatory)

Element	Attribute	Size	Input Type	Requirement
DistrictName		1 to 200 characters	stf:StringMin1Max200_Type	Optional(Mandatory)

Element	Attribute	Size	Input Type	Requirement
POB		1 to 200 characters	stf:StringMin1Max200_Type	Optional(Mandatory)

Element	Attribute	Size	Input Type	Requirement
PostCode		1 to 200 characters	stf:StringMin1Max200_Type	Optional(Mandatory)

Element	Attribute	Size	Input Type	Requirement
City		1 to 200 characters	stf:StringMin1Max200_Type	Validation

Element	Attribute	Size	Input Type	Requirement
CountrySubentity ²		1 to 200 characters	stf:StringMin1Max200_Type	Optional(Mandatory)

The above data elements comprise the AddressFix type. The “City” data element is required for schema validation. The other elements should always be included where they exist.

III. Person Party Type

The data elements in this section are used to provide identification information on individual Reporting Crypto-Asset Service Providers and Individual Crypto-Asset Users, as well as Controlling Persons of Entity Crypto-Asset Users that are Reportable Persons. This complex type is comprised of the following six data elements that are further set out below:

Element	Attribute	Size	Input Type	Requirement
ResCountryCode		2- character	iso:CountryCode_Type	Validation

Element	Attribute	Size	Input Type	Requirement
TIN		1 to 200 characters	carf:TIN_Type	Validation

Element	Attribute	Size	Input Type	Requirement
IIN		1 to 200 characters	carf:IndividualIN_Type	

Element	Attribute	Size	Input Type	Requirement
Name			carf:NamePerson_Type	Validation

Element	Attribute	Size	Input Type	Requirement
Address			carf:Address_Type	Validation

² This represents a state, region or department

Element	Attribute	Size	Input Type	Requirement
Nationality			iso:CountryCode_Type	Optional (non-CARF)

Element	Attribute	Size	Input Type	Requirement
BirthInfo				Validation

ResCountryCode

Element	Attribute	Size	Input Type	Requirement
ResCountryCode		2-character	iso:CountryCode_Type	Validation

This repeatable data element describes the residence country code(s) of the Individual Crypto-Asset User (or Controlling Person that is a Reportable Person) and the individual Reporting Crypto-Asset Service Provider and must be present in all data records. In respect of Individual Crypto-Asset Users or Controlling Persons that are Reportable Persons, this should correspond to the jurisdiction(s) of tax residence identified on the basis of the due diligence requirements of the CARF, including tax residence based on the conditions laid down in the domestic laws of Reportable Jurisdictions under which an individual is to be treated as fiscally “resident”. Such laws cover the forms of attachment to a jurisdiction which, in the domestic taxation laws, form the basis of a comprehensive taxation (full liability to tax), as well as cases where an individual is deemed, according to the taxation laws of a jurisdiction, to be resident of that jurisdiction (e.g. diplomats or other persons in government service). When more than one jurisdiction of tax residence is identified, all such jurisdictions should be reported.

In case of an individual Reporting Crypto-Asset Service Provider, the residence country code should correspond to the sending jurisdiction where the individual Reporting Crypto-Asset Service Provider has a nexus for reporting purposes under the CARF.

TIN Type

Element	Attribute	Size	Input Type	Requirement
TIN		1 to 200 characters	carf:TIN_Type	Validation

This repeatable data element provides the tax identification number (TIN) and follows the structure set out in Section II above. It reflects the TIN used by the tax administration of the jurisdiction of residence of the individual. In case an Individual Crypto-Asset User or Controlling Person does not have a TIN because one was not issued by the reportable jurisdiction or the domestic law of the reportable jurisdiction does not require the collection of the TIN, the value “NOTIN” should be entered and the Unknown attribute (see below) must be set to “true”. In the case of an Individual Reporting Crypto-Asset Service Provider, if TIN is not known to the sending Competent Authority, the value “NOTIN” should be entered and the Unknown attribute (see below) must be set to “true”. Furthermore, in case more than one TIN is provided, any provided element cannot be flagged as “unknown”. This element must be present for Individual Reporting Crypto-Asset Service Providers, Individual Crypto-Asset Users and Controlling Persons.

Individual IIN

Element	Attribute	Size	Input Type	Requirement
IIN		1 to 200 characters	carf:IndividualIIN_Type	Optional (Mandatory)

[EU-Specific] This data element should be provided if an Individual Identification Number is available in respect of an Individual Crypto-Asset Service Provider.

Element	Attribute	Size	Input Type	Requirement
IIN	issuedBy	2-character	iso:CountryCode_Type	Optional (Mandatory)

This attribute describes the jurisdiction that issued the IIN. If the issuing jurisdiction is not known then this element may be omitted.

NamePerson_Type

Element	Attribute	Size	Input Type	Requirement
Name			carf:NamePerson_Type	Validation

This data element allows to report both the name at birth and the name after marriage.

Element	Attribute	Size	Input Type	Requirement
Name	nameType		Stf:OECDNameType_Enum_Type	Optional

This attribute is a qualifier to indicate the type of a particular name.

Element	Attribute	Size	Input Type	Requirement
PrecedingTitle		1 to 200 characters	stf:StringMin1Max200_Type	Optional

Element	Attribute	Size	Input Type	Requirement
Title		1 to 200 characters	stf:StringMin1Max200_Type	Optional

Element	Attribute	Size	Input Type	Requirement
FirstName		1 to 200 characters	stf:StringMin1Max200_Type	Validation

This data element is required for identifying individual Reporting Crypto-Asset Service Providers, Individual Crypto-Asset Users and Controlling Persons in the context of the CARF Schema. If no complete first name is available for an individual, an initial or NFN (“No First Name”) may be used here.

Element	Attribute	Size	Input Type	Requirement
FirstName	xnlNameType	1 to 200 characters	stf:StringMin1Max200_Type	Optional

Element	Attribute	Size	Input Type	Requirement
MiddletName		1 to 200 characters	stf:StringMin1Max200_Type	Optional

This data element allows the individual’s Middle Name to be entered.

Element	Attribute	Size	Input Type	Requirement
MiddletName	xnlNameType	1 to 200 characters	stf:StringMin1Max200_Type	Optional

Element	Attribute	Size	Input Type	Requirement
NamePrefix		1 to 200 characters	stf:StringMin1Max200_Type	Optional

Element	Attribute	Size	Input Type	Requirement
NamePrefix	xnlNameType	1 to 200 characters	stf:StringMin1Max200_Type	Optional

Element	Attribute	Size	Input Type	Requirement
LastName		1 to 200 characters	stf:StringMin1Max200_Type	Validation

This data element is required. This field can include any prefix or suffix legally used by the individual Reporting Crypto-Asset Service Provider, Individual Crypto-Asset User or Controlling Person.

As the element is a string it is possible to use this for a free format name or two last names although wherever possible the structured first name and last name should be used.

Element	Attribute	Size	Input Type	Requirement
LastName	xnlNameType	1 to 200 characters	stf:StringMin1Max200_Type	Optional

Element	Attribute	Size	Input Type	Requirement
GenerationIdentifier		1 to 200 characters	stf:StringMin1Max200_Type	Optional

Element	Attribute	Size	Input Type	Requirement
Suffix		1 to 200 characters	stf:StringMin1Max200_Type	Optional

Element	Attribute	Size	Input Type	Requirement
GeneralSuffix		1 to 200 characters	stf:StringMin1Max200_Type	Optional

Address (Address_Type)

The Address element is further comprised of the same elements as previously set out in relation to OrganisationParty_Type.

Nationality

Element	Attribute	Size	Input Type	Requirement
Nationality			iso:CountryCode_Type	Optional (non-CARF)

The nationality element is not to be provided as part of the CARF schema.

Birth Info

Element	Attribute	Size	Input Type	Requirement
BirthInfo				Validation

The Birth Info element contains the birth information of individual Reporting Crypto-Asset Service Providers, Individual Crypto-Asset Users and Controlling Persons.

Element	Attribute	Size	Input Type	Requirement
BirthDate			xsd:date	Validation

This data element is required and identifies the date of birth. The data format is yyyy-MM-DD. The default value to be entered in respect of individual Reporting Crypto-Asset Service Providers is "1900-01-01".

Element	Attribute	Size	Input Type	Requirement
BirthPlace			carf:BirthPlace_Type	Optional (Mandatory)

This data element allows to give information on the place of birth.

Birth Place (BirthPlace_Type)

This is a datatype for providing information about the place of birth of the Individual Crypto-Asset User or Controlling Person that is a Reportable Person. The three data elements below may be provided in

accordance with the CARF where the Reporting Crypto-Asset Service Provider is required to obtain and report the information under domestic law, and it is available in its electronically searchable records. In this case, at the minimum the city and country of birth must also be provided.

Element	Attribute	Size	Input Type	Requirement
City		1 to 200 characters	stf:StringMin1Max200_Type	Validation

Element	Attribute	Size	Input Type	Requirement
CitySubentity		1 to 200 characters	stf:StringMin1Max200_Type	Optional

Element	Attribute	Size	Input Type	Requirement
CountryInfo				Validation

This required data element gives a choice between a current jurisdiction (identified by 2-character country code) or a former jurisdiction (identified by name). One or the other should be supplied if place of birth is reported, together with City or City and City Subentity. The Former Country Name element should be used in case the person was born in a country that has since ceased to exist.

Element	Attribute	Size	Input Type	Requirement
CountryCode		2-character	iso:CountryCode_Type	Validation(Choice)

Element	Attribute	Size	Input Type	Requirement
FormerCountryName		1 to 200 characters	stf:StringMin1Max200_Type	Validation(Choice)

IV. CARF Body

The CARF Body element contains the information on the Reporting Crypto-Asset Service Providers, Crypto-Asset Users (including Controlling Persons of certain Entity Crypto-Asset Users identified on the basis of the due diligence procedures of the CARF), as well as information on the Relevant Transactions such Crypto-Asset Users have engaged in.

Element	Attribute	Size	Input Type	Requirement
CARFBody			carf:CARFBody_Type	Optional (Mandatory)

The CARF Body element is composed of the following two correctable elements, of which details are set out further below.

Element	Attribute	Size	Input Type	Requirement
RCASP			carf:RCASP_Type	Validation

Element	Attribute	Size	Input Type	Requirement
CryptoUsers			carf:CryptoUsers_Type	Optional (Mandatory)

RCASP (Reporting Crypto-Asset Service Provider)

Element	Attribute	Size	Input Type	Requirement
RCASP			carf:RCASP_Type	Validation

The RCASP element identifies the Reporting Crypto-Asset Service Provider and its nexus to the reporting jurisdiction. It is comprised of the following four elements, of which details are set out further below.

Element	Attribute	Size	Input Type	Requirement
RCASP ID				Validation (choice)

Element	Attribute	Size	Input Type	Requirement
Nexus			carf:Nexus_EnumType	Optional (Mandatory)

Element	Attribute	Size	Input Type	Requirement
OtherNexus				Optional

Element	Attribute	Size	Input Type	Requirement
DocSpec			carf:DocSpec_Type	Validation

DocSpec identifies the particular report within the CARF message being transmitted. It allows for identification of reports requiring correction (see also guidance on Corrections below).

RCASP ID

Element	Attribute	Size	Input Type	Requirement
RCASP ID				Validation

The RCASP ID element identifies the Reporting Crypto-Asset Service Provider and allows a choice between the Entity and Individual elements, depending on whether the Reporting Crypto-Asset Service Provider is an Entity or an individual.

Element	Attribute	Size	Input Type	Requirement
Entity			carf:OrganisationParty_Type	Validation (choice)

The Entity element follows the Organisation Party Type set out in Section II above.

Element	Attribute	Size	Input Type	Requirement
Individual			carf:PersonParty_Type	Validation (choice)

The Individual element follows the Person Party Type set out in Section III above.

Nexus

Element	Attribute	Size	Input Type	Requirement
Nexus			carf:Nexus_EnumType	Optional (Mandatory)

The Nexus element contains information on the (strongest) nexus based on which the Reporting Crypto-Asset Service Provider is reporting under the CARF. One of the seven following values must be selected to indicate the relevant reporting nexus:

- CARF901 – Tax Residence
This value indicates that the Entity or individual Reporting Crypto-Asset Service Provider is reporting in the jurisdiction where it is resident for tax purposes.
- CARF902 – Incorporation
This value indicates that the Entity Reporting Crypto-Asset Service Provider is reporting in the jurisdiction under the laws of which it is incorporated or organised and either has legal personality in such jurisdiction or has an obligation to file tax returns or tax information returns to the tax authorities in such jurisdiction with respect to the income of the Entity.

- **CARF903 – Management**
This value indicates that the Entity Reporting Crypto-Asset Service Provider is reporting in the jurisdiction where it is managed from.
- **CARF904 – Place of Business**
This value indicates that the Entity or individual Reporting Crypto-Asset Service Provider is reporting in the jurisdiction where it has a regular place of business.
- **CARF905 – Branch**
This value indicates that the Entity Reporting Crypto-Asset Service Provider maintains a branch in the jurisdiction in respect of which it is reporting.
- **CARF906 – Authorisation**
[EU specific] This value indicates that the Reporting Crypto-Asset Service Provider is reporting in the EU Member State where it is authorised under Regulation 2023/1114
- **CARF907 – Remote Services**
[EU specific] This value indicates that the Reporting Crypto-Asset Service Provider that is not authorised under Regulation 2023/1114 is reporting in the EU Member State of single registration.

Other Nexus

Element	Attribute	Size	Input Type	Requirement
OtherNexus				Optional

This optional element, which jurisdictions may choose to use for domestic reporting purposes or in order to notify the concerned partner jurisdiction, indicates that Reporting Crypto-Asset Service Provider has an equivalent or stronger nexus in another jurisdiction, whereby reporting under the CARF will take place in such jurisdiction. This element is comprised of the following two sub-elements:

Element	Attribute	Size	Input Type	Requirement
OtherNexus	Nexus		carf:Nexus_EnumType	Validation

This element reflects the type of nexus under which reporting will take place in the other jurisdiction.

Element	Attribute	Size	Input Type	Requirement
OtherNexus	ResCountryCode	2-character	iso:CountryCode_Type	Validation

This element contains the residence country code of the other jurisdiction where reporting under the CARF is taking place.

Crypto Users

Element	Attribute	Size	Input Type	Requirement
CryptoUsers				Optional (Mandatory)

This element contains the identification information on each Crypto-Asset User (including on Controlling Persons of certain Entity Crypto-Asset Users), as well as information on the Relevant Transactions carried out by a Crypto-Asset User that are reportable under the CARF.

This element is not required to be completed with Crypto-Asset User information in instances where the report is being exchanged pursuant to an agreement between jurisdictions solely with the purpose of indicating that the Reporting Crypto-Asset Service Provider has a nexus in the sending jurisdiction for the purposes of the CARF.

This correctable element is composed of:

Element	Attribute	Size	Input Type	Requirement
User ID			carf:User ID_Type	Validation

Element	Attribute	Size	Input Type	Requirement
Controlling Person			carf:ControllingPerson_Type	(Optional) Mandatory

Element	Attribute	Size	Input Type	Requirement
RelevantTransactions			carf:RelevantTransactions_Type	Validation

Element	Attribute	Size	Input Type	Requirement
DocSpec			carf:DocSpec_Type	Validation

User ID

Element	Attribute	Size	Input Type	Requirement
User ID			carf:User ID_Type	Validation

The User ID element identifies the Crypto-Asset User and allows a choice between the Entity and Individual elements, depending on whether the Crypto-Asset User is an Entity or an individual.

Element	Attribute	Size	Input Type	Requirement
Entity			carf:OrganisationParty_Type	Validation (choice)

The Entity element follows the Organisation Party Type set out in Section II above.

Element	Attribute	Size	Input Type	Requirement
Individual			carf:PersonParty_Type	Validation (choice)

The Individual element follows the Person Party Type set out in Section III above.

Controlling Person

Element	Attribute	Size	Input Type	Requirement
Controlling Person			carf:ControllingPerson_Type	(Optional) Mandatory

Provide the name of any Controlling Person that is a Reportable Person. If there is more than one Controlling Person that is a Reportable Person, then the name of all such Reportable Persons must be reported by repeating the element.

A separate report should be created with respect to each Reportable Jurisdiction that has been identified as a jurisdiction of residence of the Controlling Persons who are Reportable Persons. However, only information of the Reportable Persons of each Reportable Jurisdiction (including information of the Entity Crypto-Asset User and other associated data) should be included in the report.

Where an Entity Crypto-Asset User is a Reportable Person and has one or more Controlling Persons that are Reportable Persons, and both the Entity and any of such Controlling Persons are resident in the same Reportable Jurisdiction, the information may be reported (i) together, as an Entity Crypto-Asset User with a Controlling Person that is a Reportable Person, or (ii) separately, as an Entity Crypto-Asset User that is a Reportable Person and a Controlling Person that is a Reportable Person.

Where none of such Controlling Persons is resident in the same Reportable Jurisdiction as the Entity, the information with respect to the Entity Crypto-Asset User must nevertheless be reported separately as an Entity that is a Reportable Person.

Element	Attribute	Size	Input Type	Requirement
Individual			carf:PersonParty_Type	Validation

The Individual element follows the Person Party Type set out in Section III above.

Element	Attribute	Size	Input Type	Requirement
CtrlgPersonType			carf:CtrlgPersonType_EnumType	Validation

This data element allows the identification of the type of each Controlling Person (“CP”) by use of the attribute “ControllingPersonType” with the following values. This element can be repeated.

- CARF801 – CP of legal person – ownership
- CARF802 – CP of legal person – other means
- CARF803 – CP of legal person – senior managing official
- CARF804 – CP of legal arrangement – trust – settlor
- CARF805 – CP of legal arrangement – trust – trustee
- CARF806 – CP of legal arrangement – trust – protector
- CARF807 – CP of legal arrangement – trust – beneficiary
- CARF808 – CP of legal arrangement – trust – other
- CARF809 – CP of legal arrangement – other – settlor-equivalent
- CARF810 – CP of legal arrangement – other – trustee-equivalent
- CARF811 – CP of legal arrangement – other – protector-equivalent
- CARF812 – CP of legal arrangement – other – beneficiary-equivalent
- CARF813 – CP of legal arrangement – other – other-equivalent

Relevant Transactions

Element	Attribute	Size	Input Type	Requirement
RelevantTransactions			carf:RelevantTransactions_Type	Validation

The repeatable Relevant Transactions element includes information on the Relevant Transactions carried out by a Crypto-Asset User during the reporting period for each Relevant Crypto-Asset type. This element is comprised of several elements reflecting the different categories of transactions reportable under the CARF, as well as of an attribute to identify each Relevant Crypto-Asset type. As such, the Relevant Transaction element should be repeated for each Relevant Crypto-Asset type in respect of which the Crypto-Asset User carried out Relevant Transactions in the reporting year.

Element	Attribute	Size	Input Type	Requirement
CryptoAsset		1-200 Character	Stf:StringMin1Max200_Type	Validation

The Crypto Asset element should include the name of the Relevant Crypto-Asset for which the transactional information is completed. The Crypto-Asset name should be reported in line with the Digital Token Identifier, whenever feasible. Further specifications on the naming convention for Crypto-Assets may be made available on the OECD website [to include link once developed]. For Crypto-Assets not reflected on the OECD website, Reporting Crypto-Asset Service Providers may rely on any other available, commonly-used naming conventions. Where no naming convention is available in respect of a Crypto-Asset, Reporting Crypto-Asset Service Providers may report the name of the Crypto-Asset using free text.

Crypto to Crypto In

Element	Attribute	Size	Input Type	Requirement
CryptotoCryptoIn				Optional (Mandatory)

The Crypto to Crypto In element reflects information on acquisitions of the Relevant Crypto-Asset against other Relevant Crypto-Assets during the reporting period.

Element	Attribute	Size	Input Type	Requirement
ExchangeType			carf:ExchangeType_EnumType	Optional

Where applicable, the optional Exchange Type allows the Reporting Crypto-Asset Service Provider to provide additional information on certain types of exchange transactions. Possible values are:

- CARF401 – Staking
- CARF402 – Crypto Loan
- CARF403 – Wrapping
- CARF404 – Collateral

Element	Attribute	Size	Input Type	Requirement
NumberOfTransactions			xsd:integer	Validation

The Number of Transactions element reflects information on the number of transactions involving acquisitions of the Relevant Crypto-Asset against other Relevant Crypto-Assets.

Element	Attribute	Size	Input Type	Requirement
Amount			cfc:MonAmnt_Type	Validation

The Amount element reflects the aggregate fair market value of the Relevant Crypto-Asset acquired, net of transaction fees. Amounts are entered with 2-digit fractional amounts of the currency in question. For example, USD 1 000 would be entered as 1000.00.

Element	Attribute	Size	Input Type	Requirement
Amount	currCode	3 characters	iso:currCode_Type	Validation

All amounts must be accompanied by the appropriate 3 character currency code based on the ISO 4217 Alpha 3 standard.

Element	Attribute	Size	Input Type	Requirement
NumberOfUnits			xsd:decimal	Validation

The Number of Units element reflects the number of units of the Relevant Crypto-Asset acquired, which should be reported up to the sixth decimal place, where relevant.

Crypto to Crypto Out

Element	Attribute	Size	Input Type	Requirement
CryptotoCryptoOut				Optional (Mandatory)

The Crypto to Crypto Out element reflects information on disposals of the Relevant Crypto-Asset against other Relevant Crypto-Assets during the reporting period.

Element	Attribute	Size	Input Type	Requirement
ExchangeType			carf:ExchangeType_EnumType	Optional

Where applicable, the optional Exchange Type allows the Reporting Crypto-Asset Service Provider to provide additional information on certain types of exchange transactions. Possible values are:

- CARF401 – Staking

- CARF402 – Crypto Loan
- CARF403 – Wrapping
- CARF404 – Collateral

Element	Attribute	Size	Input Type	Requirement
NumberOfTransactions			xsd:integer	Validation

The Number of Transactions element reflects information on the number of transactions involving disposals of the Relevant Crypto-Asset against other Relevant Crypto-Assets.

Element	Attribute	Size	Input Type	Requirement
Amount			cfc:MonAmnt_Type	Validation

The Amount element reflects the aggregate fair market value of the Relevant Crypto-Asset disposed, net of transaction fees. Amounts are entered with 2-digit fractional amounts of the currency in question. For example, USD 1 000 would be entered as 1000.00.

Element	Attribute	Size	Input Type	Requirement
Amount	currCode	3 characters	iso:currCode_Type	Validation

All amounts must be accompanied by the appropriate 3 character currency code based on the ISO 4217 Alpha 3 standard.

Element	Attribute	Size	Input Type	Requirement
NumberOfUnits			xsd:decimal	Validation

The Number of Units element reflects the number of units of the Relevant Crypto-Asset disposed, which should be reported up to the sixth decimal place, where relevant.

Crypto to Fiat In

Element	Attribute	Size	Input Type	Requirement
CryptoFiatIn				Optional (Mandatory)

The Crypto to Fiat In element reflects information on acquisitions of the Relevant Crypto-Asset against Fiat Currency during the reporting period.

Element	Attribute	Size	Input Type	Requirement
ExchangeType			carf:ExchangeType_EnumType	Optional

Where applicable, the optional Exchange Type allows the Reporting Crypto-Asset Service Provider to provide additional information on certain types of exchange transactions. Possible values are:

- CARF401 – Staking
- CARF402 – Crypto Loan
- CARF403 – Wrapping
- CARF404 – Collateral

Element	Attribute	Size	Input Type	Requirement
NumberOfTransactions			xsd:integer	Validation

The Number of Transactions element reflects information on the number of transactions involving acquisitions of the Relevant Crypto-Asset against Fiat Currency.

Element	Attribute	Size	Input Type	Requirement
Amount			cfc:MonAmnt_Type	Validation

The Amount element reflects the aggregate amount paid in respect of acquisitions of the Relevant Crypto-Assets against Fiat Currency, net of transaction fees. Amounts are entered with 2-digit fractional amounts of the currency in question. For example, USD 1 000 would be entered as 1000.00.

Element	Attribute	Size	Input Type	Requirement
Amount	currCode	3 characters	iso:currCode_Type	Validation

All amounts must be accompanied by the appropriate 3 character currency code based on the ISO 4217 Alpha 3 standard.

Element	Attribute	Size	Input Type	Requirement
NumberofUnits			xsd:decimal	Validation

The Number of Units element reflects the number of units of the Relevant Crypto-Asset acquired, which should be reported up to the sixth decimal place, where relevant.

Crypto to Fiat Out

Element	Attribute	Size	Input Type	Requirement
CryptoFiatOut				Optional (Mandatory)

The Crypto to Fiat Out element reflects information on disposals of the Relevant Crypto-Asset against Fiat Currency during the reporting period.

Element	Attribute	Size	Input Type	Requirement
ExchangeType			carf:ExchangeType_EnumType	Optional

Where applicable, the optional Exchange Type allows the Reporting Crypto-Asset Service Provider to provide additional information on certain types of exchange transactions. Possible values are:

- CARF401 – Staking
- CARF402 – Crypto Loan
- CARF403 – Wrapping
- CARF404 – Collateral

Element	Attribute	Size	Input Type	Requirement
NumberofTransactions			xsd:integer	Validation

The Number of Transactions element reflects information on the number of transactions involving disposals of the Relevant Crypto-Asset against Fiat Currency.

Element	Attribute	Size	Input Type	Requirement
Amount			cfc:MonAmnt_Type	Validation

The Amount element reflects the aggregate amount received in respect of disposals of the Relevant Crypto-Asset against Fiat Currency, net of transaction fees. Amounts are entered with 2-digit fractional amounts of the currency in question. For example, USD 1 000 would be entered as 1000.00.

Element	Attribute	Size	Input Type	Requirement
Amount	currCode	3 characters	iso:currCode_Type	Validation

All amounts must be accompanied by the appropriate 3 character currency code based on the ISO 4217 Alpha 3 standard.

Element	Attribute	Size	Input Type	Requirement
NumberofUnits			xsd:decimal	Validation

The Number of Units element reflects the number of units of the Relevant Crypto-Asset disposed, which should be reported up to the sixth decimal place, where relevant.

Crypto Transfer In

Element	Attribute	Size	Input Type	Requirement
CryptoTransferIn			carf:RelevantTransactions_Type	Optional (Mandatory)

The Crypto Transfer In element reflects information on inbound Transfers of the Relevant Crypto-Asset during the reporting period.

Element	Attribute	Size	Input Type	Requirement
TransferType			carf:TransferType_EnumType	Validation

The Transfer Type element reflects information on the type of inbound transfer received by the Reportable User. Possible values are:

- CARF501 – Airdrop
- CARF502 – Staking income
- CARF503 – Mining income
- CARF504 – Crypto loan
- CARF505 – Transfer from another RCASP
- CARF506 – Sale of goods or services
- CARF507 – Collateral
- CARF508 – Other
- CARF509 – Unknown (to be selected as the default value where the Reporting Crypto-Asset Service Provider has no knowledge on the Transfer Type)

Element	Attribute	Size	Input Type	Requirement
NumberOfTransactions			xsd:integer	Validation

The Number of Transactions element reflects information on the number of transactions involving inbound Transfers of the Relevant Crypto-Asset.

Element	Attribute	Size	Input Type	Requirement
Amount			cfc:MonAmnt_Type	Validation

The Amount element reflects the aggregate fair market value of the Relevant Crypto-Asset received, net of transaction fees. Amounts are entered with 2-digit fractional amounts of the currency in question. For example, USD 1 000 would be entered as 1000.00.

Element	Attribute	Size	Input Type	Requirement
Amount	currCode	3 characters	iso:currCode_Type	Validation

All amounts must be accompanied by the appropriate 3 character currency code based on the ISO 4217 Alpha 3 standard.

Element	Attribute	Size	Input Type	Requirement
NumberOfUnits			xsd:decimal	Validation

The Number of Units elements reflects the number of units of the Relevant Crypto-Asset received, which should be reported up to the sixth decimal place, where relevant.

Element	Attribute	Size	Input Type	Requirement
AltValuation			carf:AltValuation_EnumType	Optional (Mandatory)

The AltValuation element should include the alternative valuation method, when such method has been used by the Reporting Crypto-Asset Service Provider to value the Relevant Crypto-Asset. Possible values are:

- CARF1001 – Book value
- CARF1002 – Third-party value
- CARF1003 – Recent RCASP valuation
- CARF1004 – Reasonable estimate by RCASP

Crypto Transfer Out

Element	Attribute	Size	Input Type	Requirement
CryptoTransferOut				Optional (Mandatory)

The Crypto Transfer Out element reflects information on outbound Transfers of the Relevant Crypto-Asset during the reporting period.

Element	Attribute	Size	Input Type	Requirement
TransferType			carf: TransferOutType_EnumType	Validation

The Transfer Type element reflects information on the type of outbound transfer. Possible values are:

- CARF601 – Transfer to another RCASP
- CARF602 – Crypto loan
- CARF603 – Purchase of goods or services, to be used in respect of transactions other than those already reported as Reportable Retail Payment Transactions
- CARF604 – Collateral
- CARF605 – Other
- CARF606 – Unknown (to be selected as the default value where the Reporting Crypto-Asset Service Provider has no knowledge on the Transfer Type)

Element	Attribute	Size	Input Type	Requirement
NumberOfTransactions			xsd:integer	Optional (Mandatory)

The Number of Transactions element reflects information on the number of transactions involving outbound Transfers of the Relevant Crypto-Asset.

Element	Attribute	Size	Input Type	Requirement
Amount			cfc:MonAmnt_Type	Validation

The Amount element reflects the aggregate fair market value of the Relevant Crypto-Asset transferred, net of transaction fees. Amounts are entered with 2-digit fractional amounts of the currency in question. For example, USD 1 000 would be entered as 1000.00.

Element	Attribute	Size	Input Type	Requirement
Amount	currCode	3 characters	iso:currCode_Type	Validation

All amounts must be accompanied by the appropriate 3 character currency code based on the ISO 4217 Alpha 3 standard.

Element	Attribute	Size	Input Type	Requirement
NumberOfUnits			xsd:decimal	Validation

The Number of Units element reflects the number of units of the Relevant Crypto-Asset transferred, which should be reported up to the sixth decimal place, where relevant.

Element	Attribute	Size	Input Type	Requirement
AltValuation			carf:AltValuation_EnumType	Optional (Mandatory)

The AltValuation element should include the alternative valuation method, when such method has been used by the Reporting Crypto-Asset Service Provider to value the Relevant Crypto-Asset. Possible values are:

- CARF1001 – Book value
- CARF1002 – Third-party value
- CARF1003 – Recent RCASP valuation
- CARF1004 – Reasonable estimate by RCASP

Transfer Wallet

Element	Attribute	Size	Input Type	Requirement
TransferWallet				Optional (Mandatory)

The Transfer Wallet element reflects information in respect of Transfers of the Relevant Crypto-Asset by the Reportable Crypto-Asset User to wallet addresses not known by the Reporting Crypto-Asset Service Provider to be associated with a virtual asset service provider or financial institution.

Element	Attribute	Size	Input Type	Requirement
Amount			cfc:MonAmnt_Type	Validation

The Amount element reflects the aggregate fair market value of the Relevant Crypto-Asset transferred to wallet addresses not known by the Reporting Crypto-Asset Service Provider to be associated with a virtual asset service provider or financial institution. Amounts are entered with 2-digit fractional amounts of the currency in question. For example, USD 1 000 would be entered as 1000.00.

Element	Attribute	Size	Input Type	Requirement
Amount	currCode	3 characters	iso:currCode_Type	Validation

All amounts must be accompanied by the appropriate 3 character currency code based on the ISO 4217 Alpha 3 standard.

Element	Attribute	Size	Input Type	Requirement
NumberofUnits			xsd:decimal	Validation

The Number of Units element reflects the number of units of the Relevant Crypto-Asset transferred to wallet addresses not known by the Reporting Crypto-Asset Service Provider to be associated with a virtual asset service provider or financial institution. The number of units should be reported up to the sixth decimal place, where relevant.

Element	Attribute	Size	Input Type	Requirement
AltValuation			carf:AltValuation_EnumType	Optional (Mandatory)

The AltValuation element should include the alternative valuation method, when such method has been used by the Reporting Crypto-Asset Service Provider to value the Relevant Crypto-Asset. Possible values are:

- CARF1001 – Book value
- CARF1002 – Third-party value
- CARF1003 – Recent RCASP valuation
- CARF1004 – Reasonable estimate by RCASP

RRPT

Element	Attribute	Size	Input Type	Requirement
RRPT				Optional (Mandatory)

The RRPT element reflects information in respect of Reportable Retail Payment Transactions, i.e. Transfers of a Relevant Crypto-Asset in consideration of goods or services for a value exceeding USD 50,000, irrespective of rounding (i.e. a Transfer in consideration of goods or services for a value of USD 50,001 could be considered a Reportable Retail Payment Transaction).

Element	Attribute	Size	Input Type	Requirement
NumberOfTransactions			xsd:integer	Validation

The Number of Transactions element reflects information on the number of Reportable Retail Payment Transactions involving the Relevant Crypto-Asset.

Element	Attribute	Size	Input Type	Requirement
Amount			cfc:MonAmnt_Type	Validation

The Amount element reflects the aggregate fair market value of the Relevant Crypto-Asset subject to the Reportable Retail Payment Transactions, net of transaction fees. Amounts are entered with 2-digit fractional amounts of the currency in question. For example, USD 1 000 would be entered as 1000.00.

Element	Attribute	Size	Input Type	Requirement
Amount	currCode	3 characters	iso:currCode_Type	Validation

All amounts must be accompanied by the appropriate three-character currency code based on the ISO 4217 Alpha 3 standard.

Element	Attribute	Size	Input Type	Requirement
NumberOfUnits			xsd:decimal	Validation

The Number of Units element reflects the number of units of the Relevant Crypto-Asset subject to the Reportable Retail Payment Transactions, which should be reported up to the sixth decimal place, where relevant.

Corrections

Introduction

In case the sending jurisdiction becomes aware of inaccurate information, be it in relation to the Reporting Crypto-Asset Service Provider or in relation to the reporting in respect of Crypto-Asset Users, a correction will need to be made. As long as the error is discovered prior to the exchange of the CARF information for a given fiscal year, no correction, as set out in this section, would be required.

However, in case an error is discovered after the exchange of the CARF information, adjustments to part of the schema will need to be made, in accordance with the guidance set out in this section.

In order to facilitate a targeted reporting of corrections, the CARF XML Schema has two correctable types called RCASP and Crypto Users.

Technical Guidance

This section describes how to make corrections by sending a file of corrected data that can be processed in the same manner as the original data. Reference to corrections in this section also includes deletion of records.

In order to identify the elements to correct, the correctable elements RCASP and Crypto Users include an element of the DocSpec_Type, which contains the necessary information for corrections.

DocSpec Type

Element	Attribute	Size	Input Type	Requirement
DocSpec			carf:DocSpec_Type	Validation

DocSpec identifies the particular record within the CARF message being transmitted. It permits the identification of records requiring correction. The DocSpec element is composed of the following:

Element	Attribute	Size	Input Type	Requirement
DocTypeIndic			carf:OECDDocTypeIndic_EnumType	Validation

A message can either contain new records (OECD1) or corrections and/or deletions (OECD2 and OECD3), but should not contain a mixture of both. The resend option (OECD0) can only be used for the RCASP element when the RCASP element has already been sent. The resend option (OECD0) can be used in the following two cases:

- New data: in case new Crypto Users information is provided in respect of a reporting period and the RCASP element has already been sent.
- Correction/deletion: in case the Crypto Users element is corrected (or deleted) and the RCASP element has already been sent and the RCASP element does not need to be corrected (or deleted). The RCASP element cannot be deleted without deleting all related Crypto Users information (either in same message or in previous messages).

For a correction message, the following combinations of DocTypeIndic are permissible for the correctable elements, taking into account that the CryptoUsers element is not mandatory:

		w/o Crypto Users	CryptoUsers			
			OECD1	OECD2	OECD3	OECD0
RCASP	OECD1					
	OECD2	OK		OK	OK	
	OECD3	OK			OK	
	OECD0			OK	OK	

Combinations of DocTypeIndic for the correctable elements within a correction message

This element specifies the type of data being submitted.

Allowable entries are:

- OECD0 = Resent Data
- OECD1 = New Data
- OECD2 = Corrected Data
- OECD3 = Deletion of Data
- OECD10 = Resent Test Data
- OECD11 = New Test Data
- OECD12 = Corrected Test Data
- OECD13 = Deletion of Test Data

The codes OECD10 through OECD13 must only be used during agreed testing periods or on the basis of a bilateral agreement on testing. This is to ensure that the Competent Authorities avoid test data becoming mingled with 'live' data.

Element	Attribute	Size	Input Type	Requirement
DocRefID		1 to 200 characters	carf:StringMin1Max200_Type	Validation

The DocRefID is a unique identifier for the document (i.e. one record and all its children data elements). An element containing a correction (or deletion) must have a new unique DocRefID for future reference.

Element	Attribute	Size	Input Type	Requirement
CorrDocRefID		1 to 200 characters	carf:StringMin1Max200_Type	Optional

The CorrDocRefID references the DocRefID of the element to be corrected or deleted. It must always refer to the latest reference of the record (DocRefID) that was sent.

The latest reference of the record (DocRefID) that was sent must be part of the latest message in which the record was sent.

In this way, a series of corrections or amendments can be handled as each correction completely replaces the previous version.

Uniqueness of MessageRefID and DocRefID

In order to ensure that a message and a record can be identified and corrected, the MessageRefID and DocRefID must be unique in space and time (i.e. there must be no other message or record in existence that has the same reference identifier).

The MessageRefID identifier can contain whatever information the sender uses to allow identification of the particular message but must start with the country code of the sending jurisdiction, then the year of the reportable period, then the receiving country code before a unique identifier.

e.g. CA2023LU123456789

This MessageRefID indicates that the Canada is the country of the sending Competent Authority, the receiving Competent Authority is Luxembourg and that the unique identifier is “123456789”.

The unique identifier in the DocRefID is used by the sending Competent Authority to identify a unique CARF record and is composed of the country code of the sending jurisdiction, then the year of the reportable period, followed by a unique identifier.

e.g. CA2023286abc123xyz

This DocRefID indicates that Canada is the sending country and the unique identifier is “286abc123xyz”.

MessageSpec, Corrections and Cancellations

Correction messages must have their own unique MessageRefID so they can also be corrected in the future. There is no equivalent for the DocSpec type when it comes to messages as a whole.

To cancel a complete message, there is no element in the MessageSpec which can be used for that purpose. Instead, a correction message should be sent deleting all records of the erroneous message in these instances.

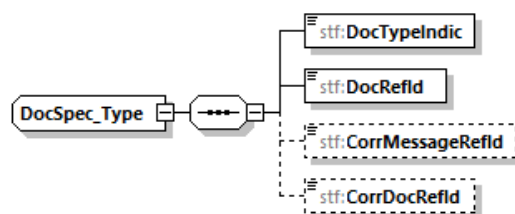

Correction examples

The following section provides two examples of concrete correction scenarios, and highlights correction rules applicable to each of them.

Correction of a child element of the Crypto User

The sending Competent Authority sends an initial message with an RCASP and Crypto User, comprised of a User ID, one Controlling Person (resident in the same jurisdiction) and a Relevant Transactions element. It then wants to correct the Address of the Controlling Person. In this case, the sending Competent Authority must correct the Crypto User element from the initial message, and send it back with the corrected Controlling Person data. It must also include the RCASP since the element is mandatory, the User ID and the Relevant Transactions; even though these elements do not require modifications. The figure below highlights this.

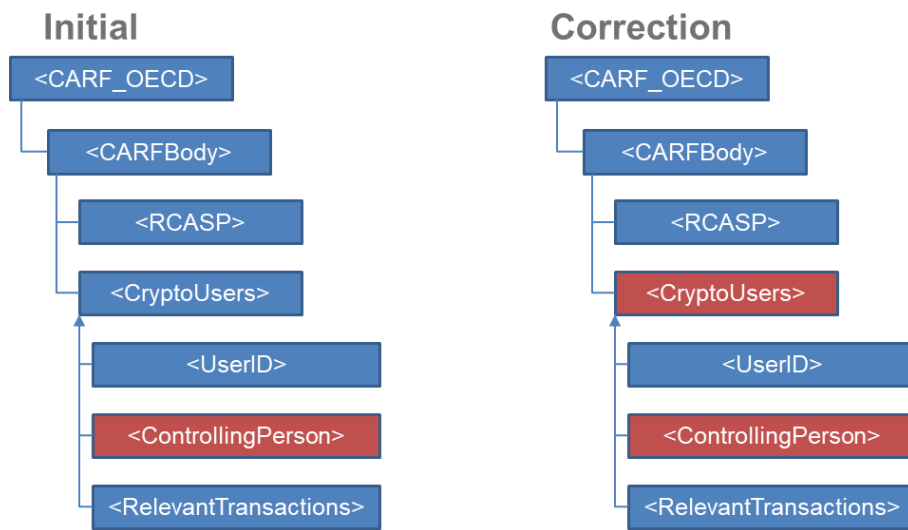

Removal of a child element of the RCASP

The sending Competent Authority sends an initial message with two Crypto User reports and the associated Entity RCASP having two Addresses. It then wants to remove the second address of the RCASP. In this case, the sending Competent Authority must correct the RCASP from the initial message, and send it back without the deleted Address but with the other Address, as well as the other child elements comprising the RCASP ID and Nexus elements. The Crypto User information, however, is not to be sent again. The figure below highlights this.

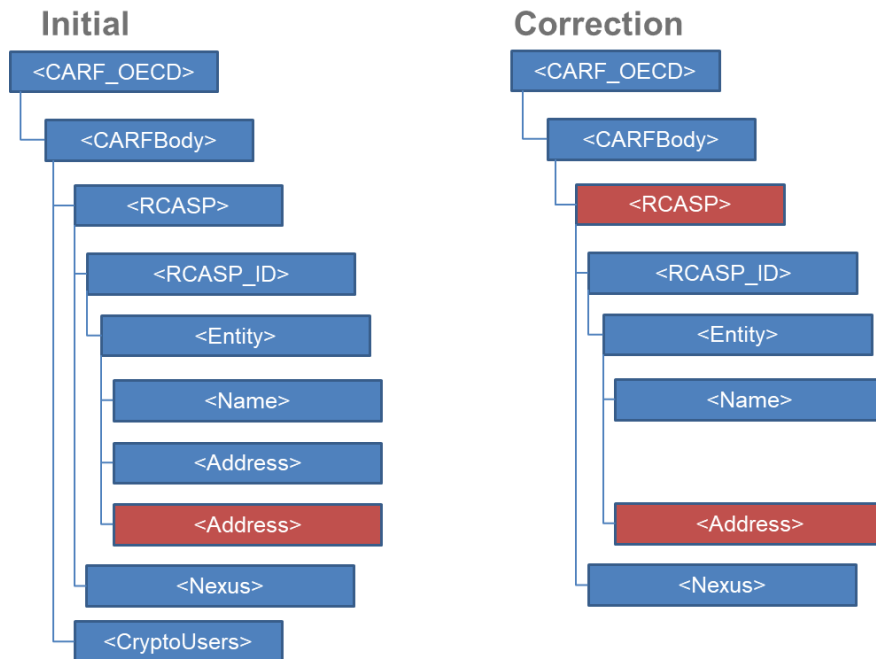

Annex A. CARF XML Schema v. 1.5 Diagrams

CARF Schema

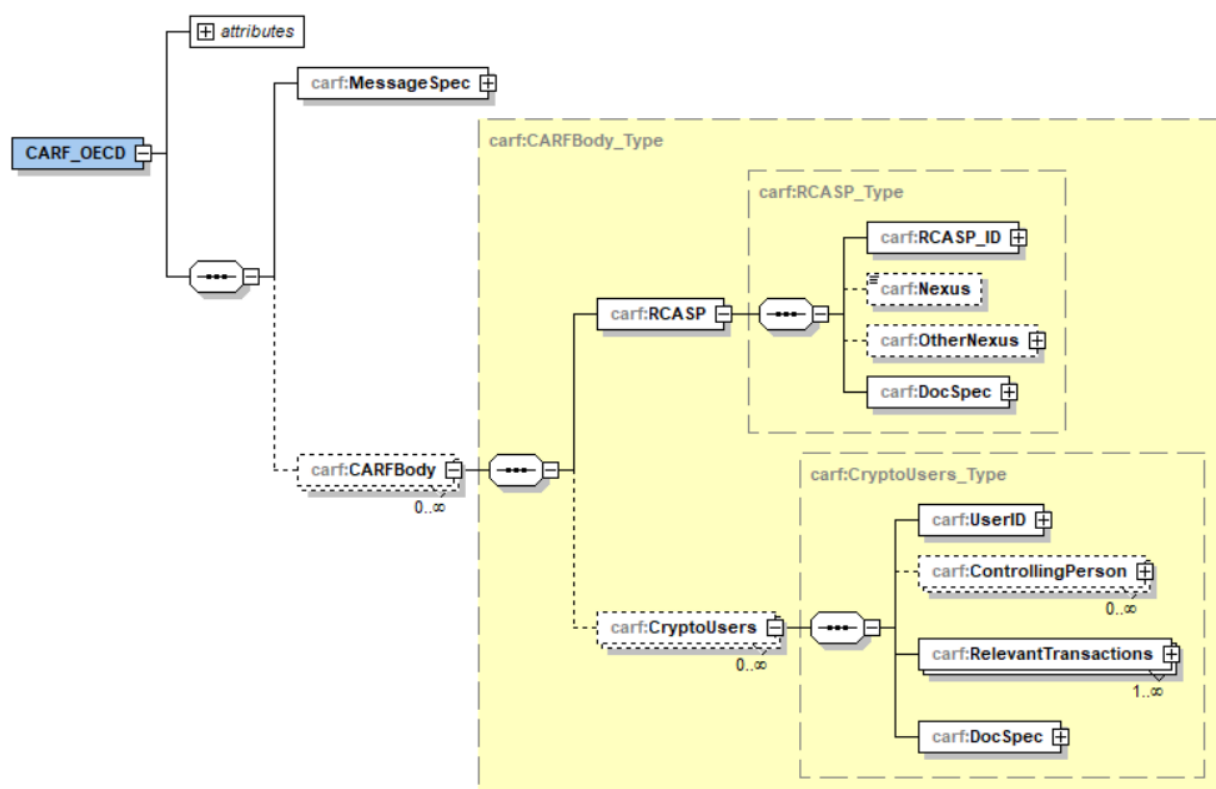

MessageSpec

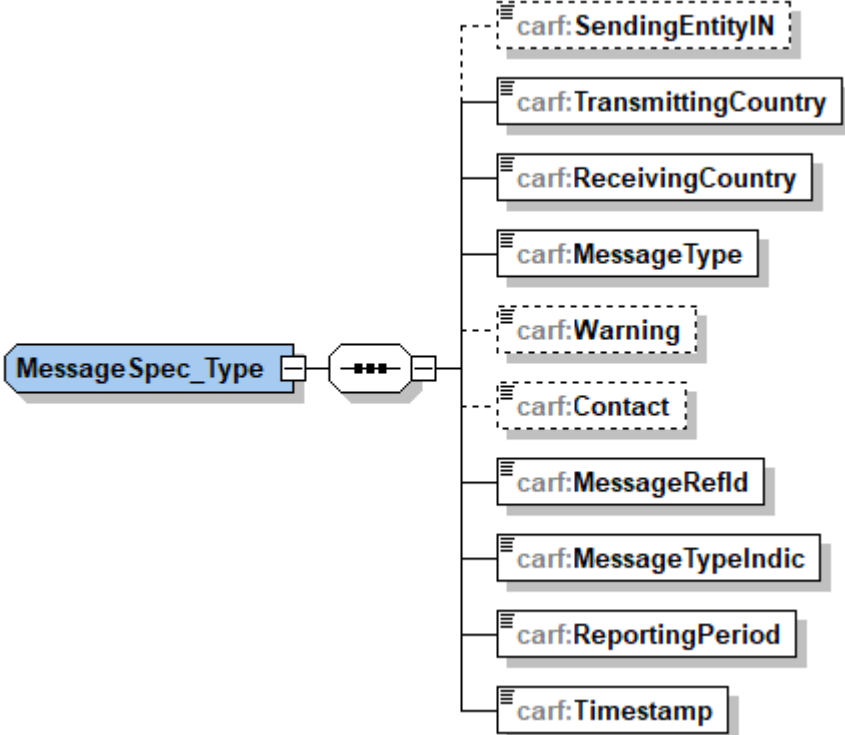

CARF Body

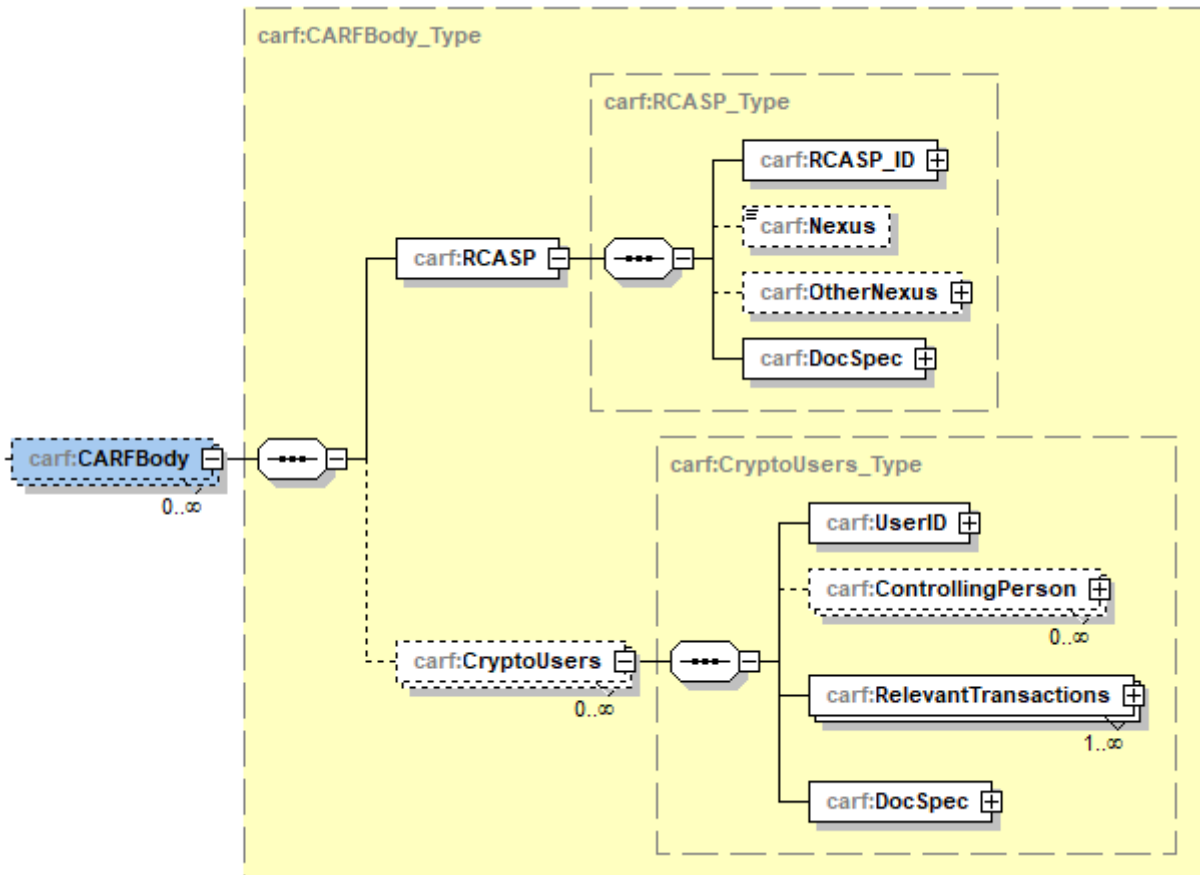

RCASP

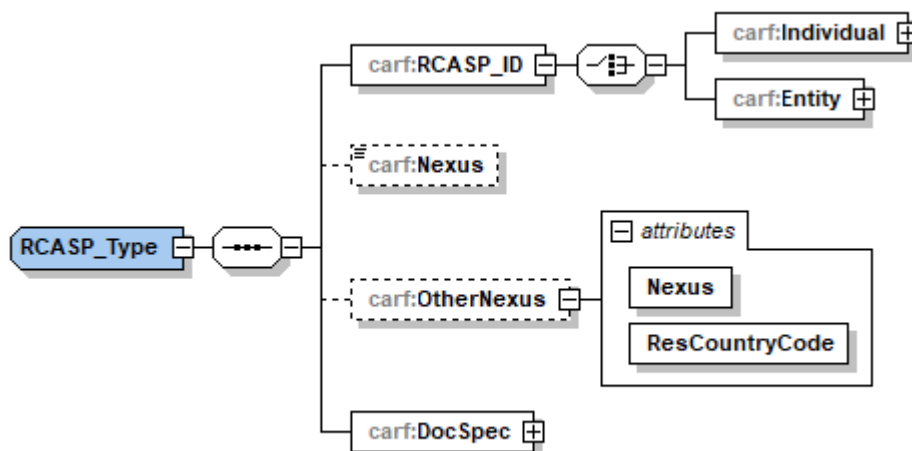

Person Party Type

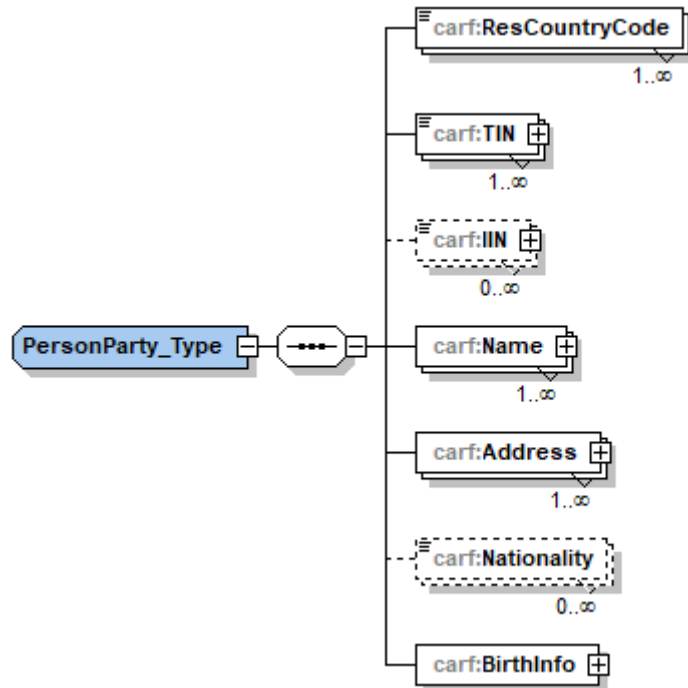

Name Person Type

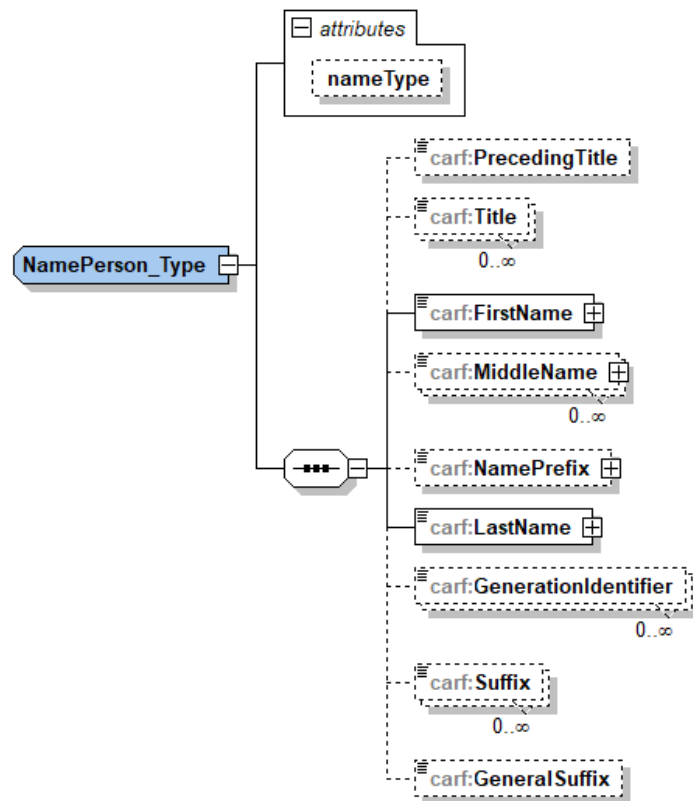

Birth Info

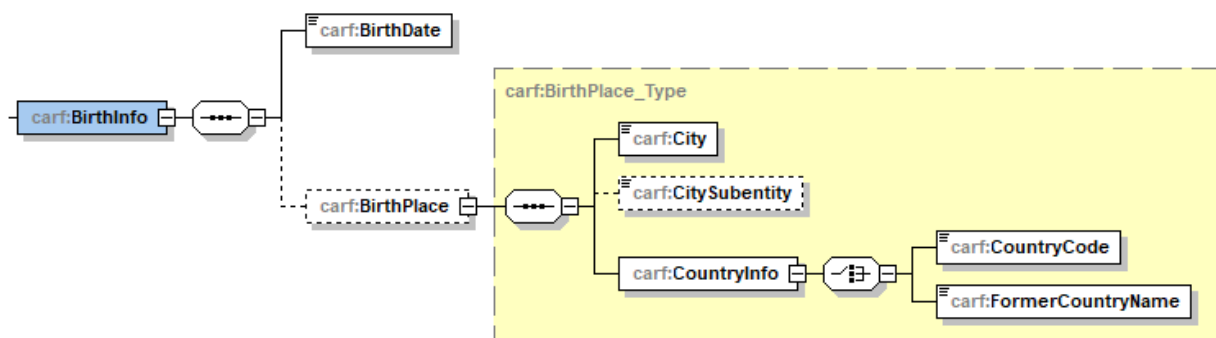

Organisation Party

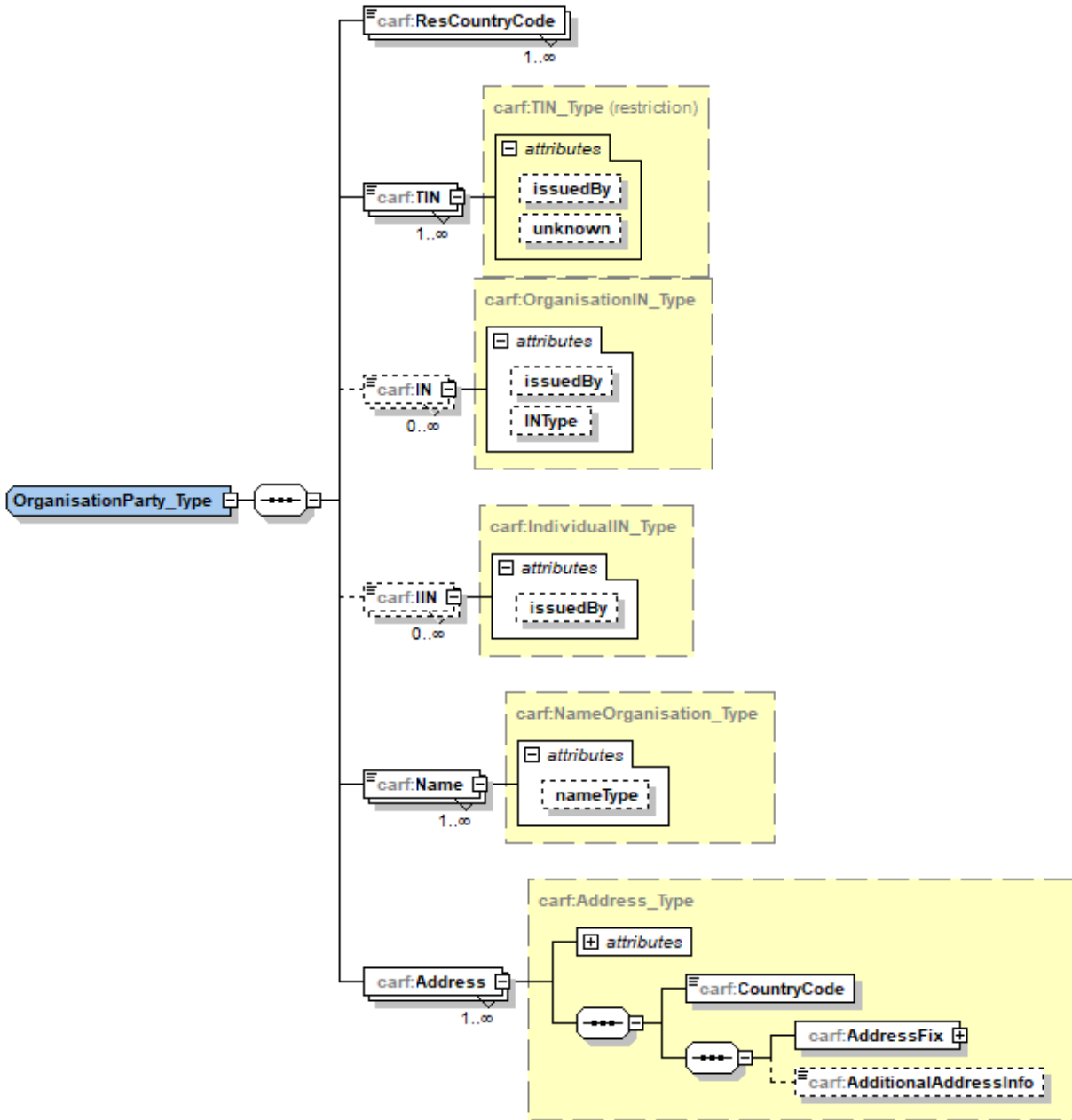

Address

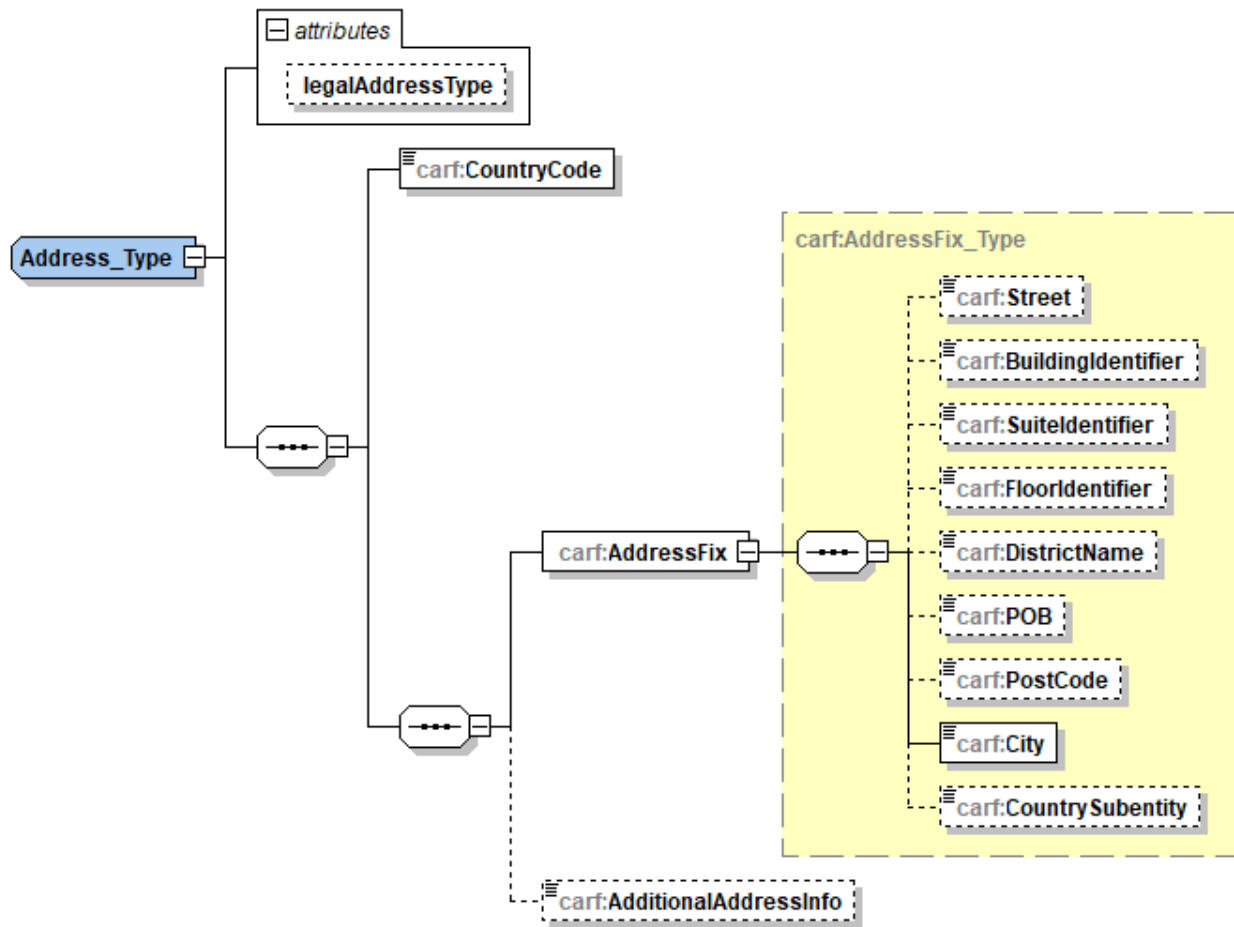

Controlling Person

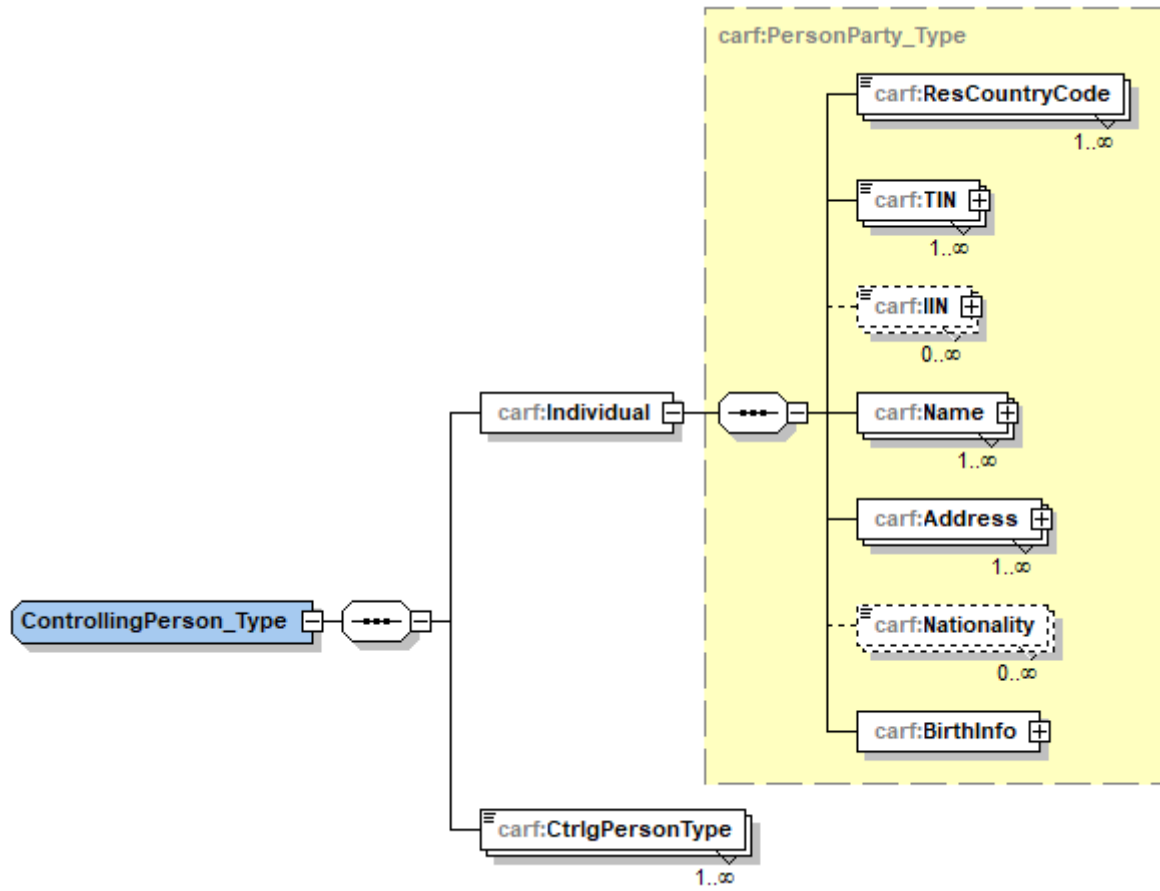

Relevant Transactions

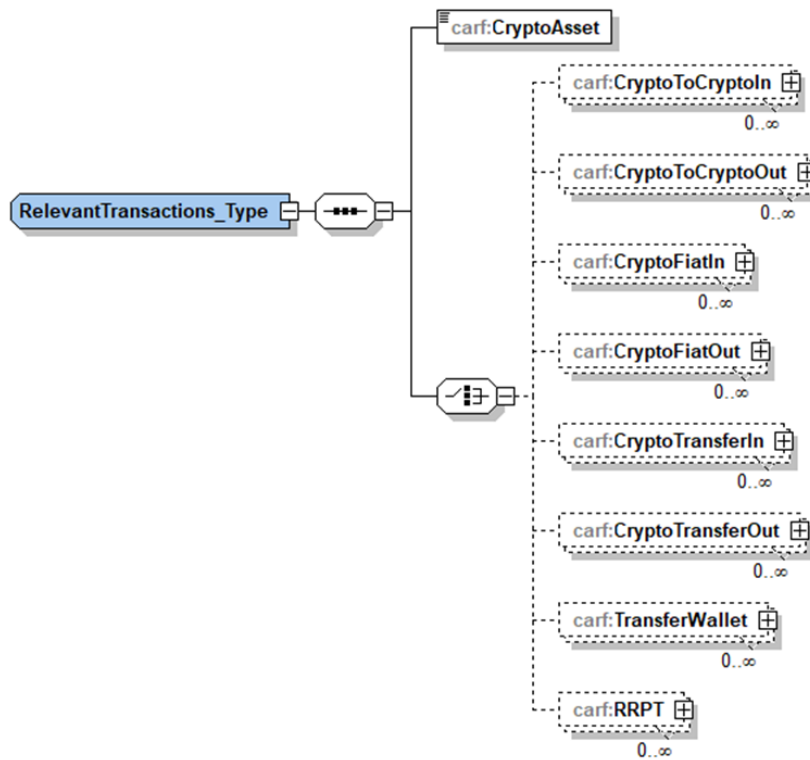

Crypto to Crypto In

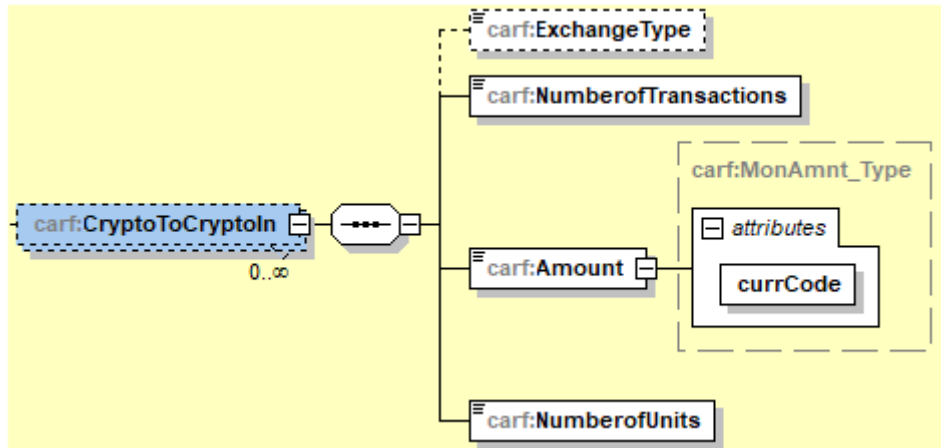

Crypto to Crypto Out

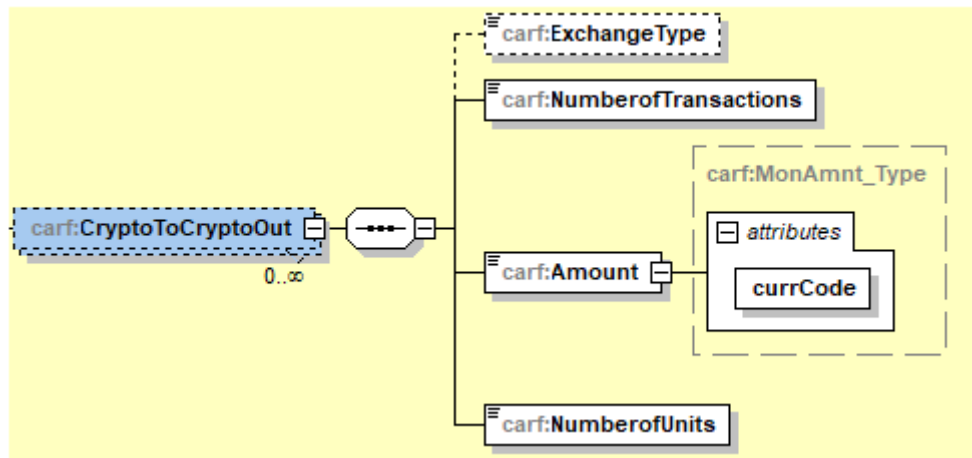

Crypto to Fiat In

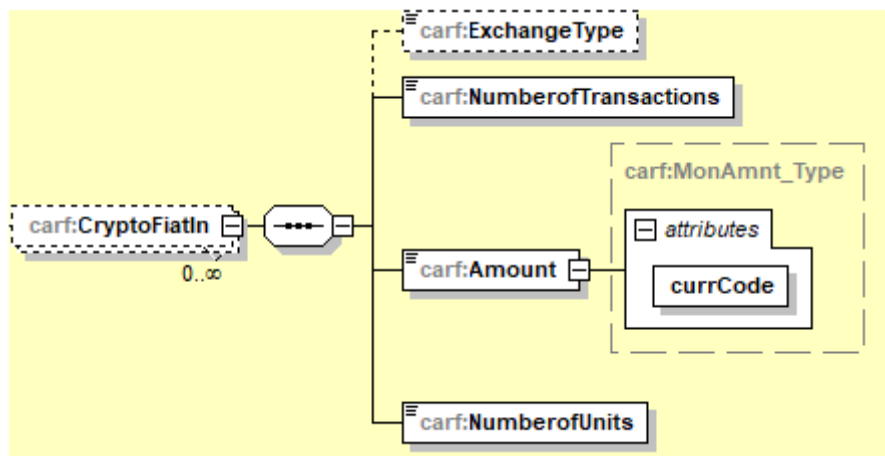

Crypto to Fiat Out

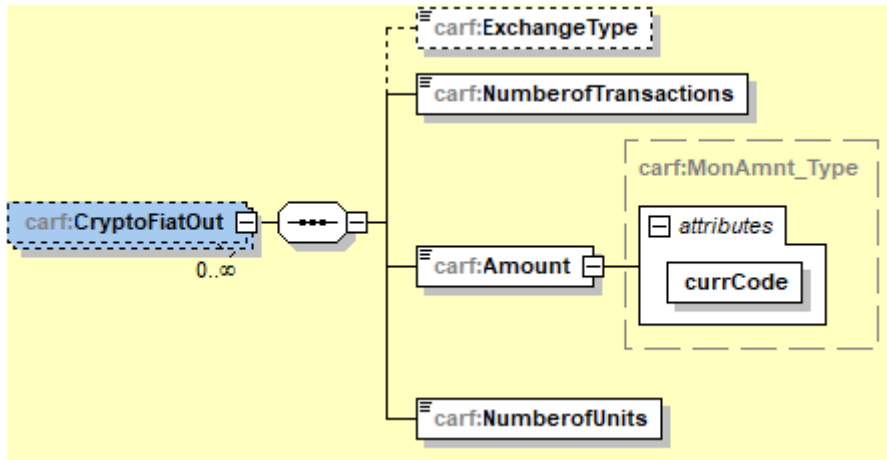

Crypto to Transfer In

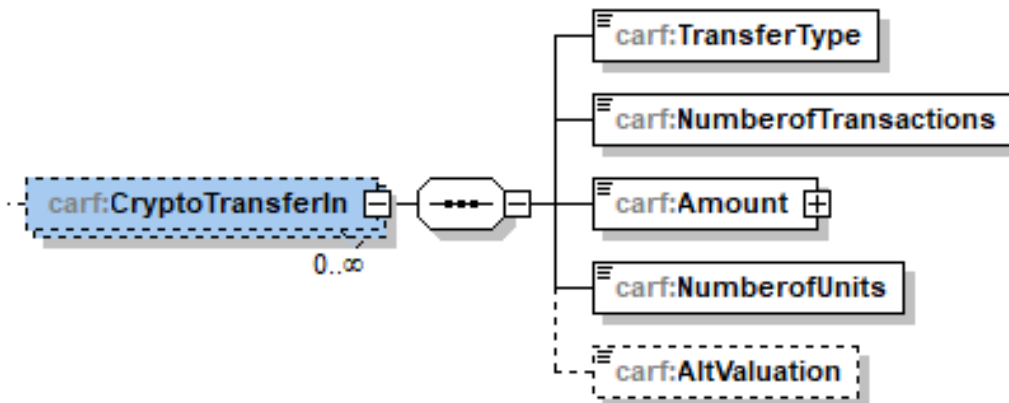

Crypto to Transfer Out

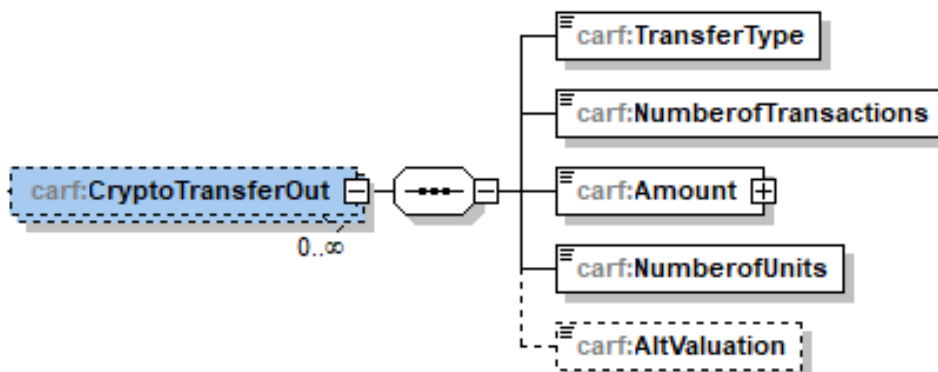

Transfer Wallet

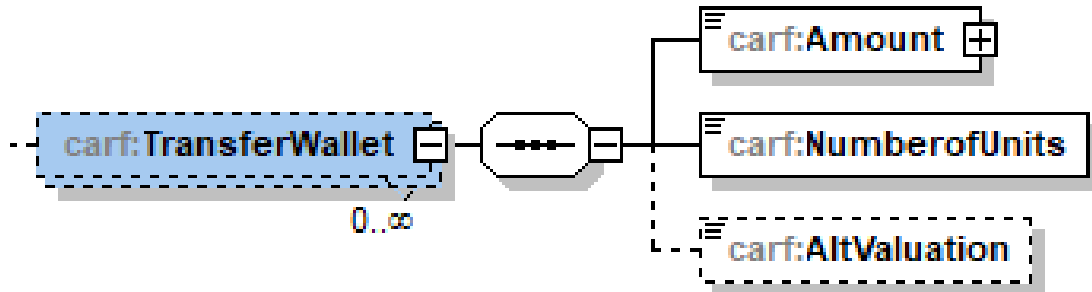

RRPT

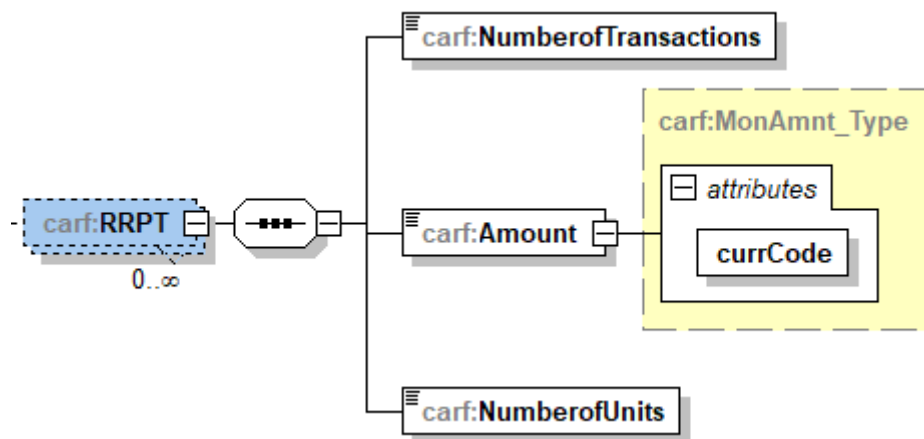

Annex B. Glossary of Namespaces

CARF XML Schema Namespaces

Namespace	Description	Filename
carf	CARF types	CARFXML_v1.5.xsd
stf	OECD Common types	OecdCARFTypes_v1.0.xsd
iso	ISO types (Country, Currency & Language codes)	IsoCARFTypes_v1.0.xsd



For more information:



ctp.contact@oecd.org



<https://oe.cd/tax>



[@OECDtax](https://twitter.com/OECDtax)



[OECD Tax](https://www.linkedin.com/company/oecd-tax)